

DRONE TECHNICIAN

NSQF LEVEL - 3

TRADE PRACTICAL

SECTOR: AEROSPACE & AVIATION

(As per revised syllabus July 2022 - 1200 Hrs)



Directorate General of Training

**DIRECTORATE GENERAL OF TRAINING
MINISTRY OF SKILL DEVELOPMENT & ENTREPRENEURSHIP
GOVERNMENT OF INDIA**



**NATIONAL INSTRUCTIONAL
MEDIA INSTITUTE, CHENNAI**

Post Box No. 3142, CTI Campus, Guindy, Chennai - 600 032

Sector : Aerospace & Aviation

Duration : Six Months

Trade : Drone Technician - Trade Practical - NSQF Level - 3 (Revised 2022)

Developed & Published by



National Instructional Media Institute

Post Box No.3142

Guindy, chennai-600 032

INDIA

Email: chennai-nimi@nic.in

Website: www.nimi.gov.in

First Edition : January 2023

Copies : 500

© NIMI
NOT TO BE REPUBLISHED

FOREWORD

The Government of India has set an ambitious target of imparting skills to 30 crores people, one out of every four Indians to help them secure jobs as part of the National Skills Development Policy. Industrial Training Institutes (ITIs) play a vital role in this process especially in terms of providing skilled manpower. Keeping this in mind, and for providing the current industry relevant skill training to Trainees, ITI syllabus has been recently updated with the help of Mentor Councils comprising various stakeholder's viz. Industries, Entrepreneurs, Academicians and representatives from ITIs.

The National Instructional Media Institute (NIMI), Chennai, an autonomous body under the Directorate General of Training (DGT), Ministry of Skill Development & Entrepreneurship is entrusted with developing producing and disseminating Instructional Media Packages (IMPs) required for ITIs and other related institutions.

The institute has now come up with instructional material to suit the revised curriculum for **Drone Technician** - Trade Practical NSQF Level - 3 (Revised 2022) in **Aerospace & Aviation** Sector under **Six Months Pattern**. The NSQF Level - 3 (Revised 2022) Trade Practical will help the trainees to get an international equivalency standard where their skill proficiency and competency will be duly recognized across the globe and this will also increase the scope of recognition of prior learning. NSQF Level - 3 (Revised 2022) trainees will also get the opportunities to promote life long learning and skill development. I have no doubt that with NSQF Level - 3 (Revised 2022) the trainers and trainees of ITIs, and all stakeholders will derive maximum benefits from these IMPs and that NIMI's effort will go a long way in improving the quality of Vocational training in the country.

The Executive Director & Staff of NIMI and members of Media Development Committee deserve appreciation for their contribution in bringing out this publication.

Jai Hind

Ms. TRISHALJIT SETHI
Addl. Secretary/Director General (Training)
Ministry of Skill Development & Entrepreneurship,
Government of India.

New Delhi - 110 001

PREFACE

The National Instructional Media Institute (NIMI) was established in 1986 at Chennai by then Directorate General of Employment and Training (D.G.E & T), Ministry of Labour and Employment, (now under Directorate General of Training, Ministry of Skill Development and Entrepreneurship) Government of India, with technical assistance from the Govt. of Federal Republic of Germany. The prime objective of this Institute is to develop and provide instructional materials for various trades as per the prescribed syllabus under the Craftsman and Apprenticeship Training Schemes.

The instructional materials are created keeping in mind, the main objective of Vocational Training under NCVT/NAC in India, which is to help an individual to master skills to do a job. The instructional materials are generated in the form of Instructional Media Packages (IMPs). An IMP consists of Theory book, Practical book, Test and Assignment book, Instructor Guide, Audio Visual Aid (Wall charts and Transparencies) and other support materials.

The trade practical book consists of series of exercises to be completed by the trainees in the workshop. These exercises are designed to ensure that all the skills in the prescribed syllabus are covered. The trade theory book provides related theoretical knowledge required to enable the trainee to do a job. The test and assignments will enable the instructor to give assignments for the evaluation of the performance of a trainee. The wall charts and transparencies are unique, as they not only help the instructor to effectively present a topic but also help him to assess the trainee's understanding. The instructor guide enables the instructor to plan his schedule of instruction, plan the raw material requirements, day to day lessons and demonstrations.

IMPs also deals with the complex skills required to be developed for effective team work. Necessary care has also been taken to include important skill areas of allied trades as prescribed in the syllabus.

The availability of a complete Instructional Media Package in an institute helps both the trainer and management to impart effective training.

The IMPs are the outcome of collective efforts of the staff members of NIMI and the members of the Media Development Committees specially drawn from Public and Private sector industries, various training institutes under the Directorate General of Training (DGT), Government and Private ITIs.

NIMI would like to take this opportunity to convey sincere thanks to the Directors of Employment & Training of various State Governments, Training Departments of Industries both in the Public and Private sectors, Officers of DGT and DGT field institutes, proof readers, individual media developers and coordinators, but for whose active support NIMI would not have been able to bring out this materials.

Chennai - 600 032

EXECUTIVE DIRECTOR

ACKNOWLEDGEMENT

National Instructional Media Institute (NIMI) sincerely acknowledges with thanks for the co-operation and contribution extended by the following Media Developers and their sponsoring organisation to bring out this IMP **(Trade Practical)** for the trade of **Drone Technician - NSQF Level - 3 (Revised 2022)** under the **Aerospace & Aviation** Sector for ITIs.

MEDIA DEVELOPMENT COMMITTEE MEMBERS

Shri. Kamil Naqvi - CEO, Hayedrone Flying Academy Pvt Ltd.
Amroha, Uttar Pradesh.

NIMI - COORDINATORS

Shri. Nirmalya Nath - Deputy Director,
NIMI, Chennai - 32.

Shri. S. Gopalakrishnan - Assistant Manager
NIMI, Chennai - 32.

NIMI records its appreciation of the Data Entry, CAD, DTP Operators for their excellent and devoted services in the process of development of this Instructional Material.

NIMI also acknowledges with thanks, the invaluable efforts rendered by all other staff who have contributed for the development of this Instructional Material.

NIMI is grateful to all others who have directly or indirectly helped in developing this IMP.

INTRODUCTION

TRADE PRACTICAL

The trade practical manual is intended to be used in practical workshop. It consists of a series of practical exercises to be completed by the trainees during the course of the **Drone Technician** trade supplemented and supported by instructions/ informations to assist in performing the exercises. These exercises are designed to ensure that all the skills in compliance with NSQF Level - 3 (Revised 2022) syllabus are covered. The manual is divided into Twelve modules.

- Module 1 - Safety Rules and Regulations
- Module 2 - Identify & Select Different Types of Drones
- Module 3 - Identify & Test Various Electronic SMD Components
- Module 4 - Measure Different Type Electrical Parameters and Record The Data Related with Drone Hardware
- Module 5 - Identification of Different Type of Batteries, Battery Specifications and Their Charging Techniques Used In Drone
- Module 6 - Identify & Select Different Types of Drones, Drone Rules and Regulations, Drone Applications, and Important Safety Precautions
- Module 7 - Identify, Select and Test Hardware Assembly, Driver For BLDC Motors
- Module 8 - Inspect, Test and Execute GPS Navigation and Telemetry Module, Different RF Blocks and Antennas Used In RF Transmitter and Receiver
- Module 9 - Test and Troubleshoot Flight Controller Board (FCB), Electronic Speed Controller (ESC) and Its Associated Peripherals
- Module 10 - Calibrate and Troubleshoot Drone Gimbal and Drone Payload
- Module 11 - Identify and Resolve Common Error Messages and Corrections By Software Debugging
- Module 12 - Inspect, Test and Execute Primary and Secondary Servicing with Troubleshoot Malfunctioning, and Repair Issues Discovered

The skill training in the shop floor is planned through a series of practical exercises centred around some practical project. However, there are few instances where the individual exercise does not form a part of project.

While developing the practical manual a sincere effort was made to prepare each exercise which will be easy to understand and carry out even by below average trainee. However the development team accept that there is a scope for further improvement. NIMI, looks forward to the suggestions from the experienced training faculty for improving the manual.

TRADE THEORY

The manual of trade theory consists of theoretical information for the Course of the **Drone Technician** Trade Theory NSQF Level - 3 (Revised 2022) in **Aerospace & Aviation**. The contents are sequenced according to the practical exercise contained in NSQF Level - 3 (Revised 2022) syllabus on Trade Theory attempt has been made to relate the theoretical aspects with the skill covered in each exercise to the extent possible. This correlation is maintained to help the trainees to develop the perceptual capabilities for performing the skills.

The trade theory has to be taught and learnt along with the corresponding exercise contained in the manual on trade practical. The indicating about the corresponding practical exercise are given in every sheet of this manual.

It will be preferable to teach/learn the trade theory connected to each exercise atleast one class before performing the related skills in the shop floor. The trade theory is to be treated as an integrated part of each exercise.

The material is not the purpose of self learning and should be considered as supplementary to class room instruction.

CONTENTS

Exercise No.	Title of the Exercise	Learning Outcome	Page No.
Module 1: Safety Rules and Regulations			
1.1.01	Visit to various sections of the institute and identify location of various installations		1
1.1.02	Identify safety symbols and hazards		3
1.1.03	Use of personal protective equipment		8
1.1.04	Practice elementary first aid		11
1.1.05	Preventive measures for electrical accidents and practice steps to be taken in such accidents	1	13
1.1.06	Use of fire extinguishers		15
1.1.07	Identify Different types of Drone		18
1.1.08	Select basic components		20
1.1.09	Apply principles of flight to Drones		21
1.1.10	Identify & prepare specific Flight Planning Procedures for specific drone flights		22
Module 2: Identify & Select Different Types of Drones			
1.2.11	Identify & select different building blocks of the drone		23
1.2.12	Test drone's different block functionality & their interconnectivity		24
1.2.13	Identify various types of body material used in drone		25
1.2.14	Recognize basic principles of flying like Bernoulli's Principle		26
1.2.15	Identify multi rotor design, various configurations, airframe sizes and their construction	2	27
1.2.16	Identify different propeller designs and design using 3D printer		30
1.2.17	Design and development of Drone's body component using 3D printer and related software		33
1.2.18	Identify type of motor used in drone		35
1.2.19	Identify & prepare specific flight planning procedures to drone flights		36
1.2.20	Practice drone flying to check to identify faults in drone		37
Module 3: Identify & Test Various Electronic SMD Components			
1.3.21	Identify of different types of SMD Components like resistance, capacitance, diode and inductor		38
1.3.22	Measure different components values using SMD Technology Kit, Tweezers and DMM	3	40
1.3.23	Identify of different types of SMD IC packages		42
1.3.24	Explore and configure SMD soldering and de-soldering rework station		43
1.3.25	Practice soldering and de-soldering the SMD components on the PCB		45
1.3.26	Practice soldering and de-solder various IC's of different packages		47
Module 4: Measure Different Type Electrical Parameters and Record The Data Related with Drone Hardware			
1.4.27	Identify the type of electronic instruments		50

Exercise No.	Title of the Exercise	Learning Outcome	Page No.
1.4.28	Measure the resistance, Voltage, Current through series and parallel connected networks using multi meter		52
1.4.29	Measure AC and DC voltage using Digital Multi-meter		54
1.4.30	Measure AC and DC current using Digital Multi-meter		56
1.4.31	Measure frequency using Digital Multi-meter	4	58
1.4.32	Measure the analog signals like of peak-to-peak voltage, frequency, time period, and duty cycle using of DSO		59
1.4.33	Measure the frequency and level of RF signals using of spectrum analyzer		63
1.4.34	Practice function generator and Arbitrary Waveform Generator		64
	Module 5: Identification of Different Type of Batteries, Battery Specifications and Their Charging Techniques Used In Drone		
1.5.35	Identify different type of batteries Li-ion and Li-Po		65
1.5.36	Record and recognize different battery specifications		66
1.5.37	Explore different charging techniques to charge batteries		67
1.5.38	Measure and record different parameters of batteries using Battery management platform	5	68
1.5.39	Inspect battery packs faults for bulges or leakage		69
1.5.40	Identify fault related with chargers such as visible damage, voltage and current		70
1.5.41	Measure and record different parameters of charging controller using software		71
1.5.42	Calculate maximum discharge and battery capacities in order calculate flight time		72
	Module 6: Identify & Select Different Types of Drones, Drone Rules and Regulations, Drone Applications, and Important Safety Precautions		
1.6.43	Identify and measure condition of drone sensors		73
1.6.44	Explore different converters like V/I, I/V, F/V, V/F		74
1.6.45	Verify frequency response of low pass and high pass filters		76
1.6.46	Test and measure different amplifier functions		77
1.6.47	Measure and record the resistance, voltage, current and frequency of different sensors used in drone	6	78
1.6.48	Test & measure accelerometers, inertial measurement units, tilt and lidar sensor, gyro sensor		79
1.6.49	Write and upload computer code to FCB to test sensors results		80
1.6.50	Calibrate the compass, Lidar, and gyro sensor		81
1.6.51	Measure and record angular rate, force, and magnetic field through IMU		82
1.6.52	Construct and test various Op-Amp circuits Inverting, Non-inverting, Summing Amplifiers		83
	Module 7: Identify, Select and Test Hardware Assembly, Driver For BLDC Motors		
1.7.53	Identify different BLDC motors and their specifications		86
1.7.54	Inspect and test BLDC Motor driver circuit	7	87
1.7.55	Measure and record speed-torque characteristics of BLDC Motor		88
1.7.56	Explore driving circuit of DC, BLDC and servo motors		89
1.7.57	Perform running and reversing phenomenon of BLDC Motor		91

Exercise No.	Title of the Exercise	Learning Outcome	Page No.
1.7.58	Demonstration speed control of BLDC Motor using PWM technique		92
1.7.59	Practice Inverted pendulum balancing using programming technique and PID tuning		93
1.7.60	Measure thrust to weight ratio and payload		94
	Module 8: Inspect, Test and Execute GPS Navigation and Telemetry Module, Different RF Blocks and Antennas Used In RF Transmitter and Receiver		
1.8.61	Identify different antennas like patch, helical, and omni-directional		95
1.8.62	Record and plot radiation pattern of different antennas		96
1.8.63	Measure directivity of the antenna		97
1.8.64	Identify the characteristics of RF circuit blocks like amplifier and filters	8	98
1.8.65	Configure and operate 433MHz and 2.4 GHz RC transmitter and receiver		99
1.8.66	Perform and check connectivity of transmitter and receiver used in drone		101
1.8.67	Understand GPS and its hardware interfacing with FCB		102
1.8.68	Connect and Measure and record data of GPS module to determine latitude & longitude		103
1.8.69	Perform experiment to record, GPGGA, GPGLL, GPGSA, GPGSV, GPRMC and GPVTG values		104
	Module 9: Test and Troubleshoot Flight Controller Board (FCB), Electronic Speed Controller (ESC) and Its Associated Peripherals		
1.9.70	Identify different flight control board and electronic speed control		107
1.9.71	Perform programming and configure flight control board (FCB)		108
1.9.72	Identify, explore and test interconnectivity of different peripheral with FCB		109
1.9.73	Establish connection of FCB with motor, GPS, ESC and sensors		110
1.9.74	Configure, test and record FCB with battery to monitor battery level and perform return to home operation		111
1.9.75	Perform and carry out drone leveling using IMU sensor	9	112
1.9.76	Perform calibration of compass, Lidar, and gyro sensor		113
1.9.77	Test communication link between FCB and RF transceiver		114
1.9.78	Write and upload computer code to FCB to test sensors results		115
1.9.79	Test and record data of motor connectivity with ESC		116
1.9.80	Perform motor rotation using FCB and ESC		117
1.9.81	Test signal flow into drone to test ESC parameters on FCB to check its operation		118
1.9.82	Write and upload computer code to FCB to ESC working		119
	Module 10: Calibrate and Troubleshoot Drone Gimbal and Drone Payload		
1.10.83	Identify the different types of drones and its application in different areas		120
1.10.84	Identify different features and controls of HD and thermal image camera	10	121
1.10.85	Test and install Gimbal camera assembly		122
1.10.86	Perform and test Gimbal stabilization		123
1.10.87	Perform drone camera control using x, y, and z axes rotation		124

Exercise No.	Title of the Exercise	Learning Outcome	Page No.
1.10.88	Test and install different cameras on gimbal assembly		125
1.10.89	Practice remote sensing, surveying & mapping, photogrammetry and precision agriculture using HD and thermal image camera		126
1.10.90	Identify and record different application drones and their logged data for investigation		127
Module 11: Identify and Resolve Common Error Messages and Corrections By Software Debugging			
1.11.91	Identify bugs in the software program as per the algorithms used and the libraries	11	128
1.11.92	Resolve common error messages and apply the correct logic		129
1.11.93	Perform firmware configuration and updates		130
1.11.94	Download and Install App / Menu / Planning / Set-up / Flight / Application		131
1.11.95	Demonstration and perform base station software to debugging to get GPS and flight data		132
1.11.96	Perform experiments on software debug tool use to identify coding errors at different stages		134
1.11.97	Setup python and Arduino environment		135
1.11.98	Remote automatic drone operation using Python		136
1.11.99	Knowledge and advantage of preventative maintenance of drone		137
1.11.100	Diagnose problems using Log Data / Analyze Data / Save Log Data / Remote Communication Log Data / Save and Execute Log Data		138
1.11.101	Upgrade/downgrade drone firmware Identify error message and resolve approach		139
Module 12: Inspect, Test and Execute Primary and Secondary Servicing with Troubleshoot Malfunctioning, and Repair Issues Discovered			
1.12.102	Perform primary and secondary servicing based upon the checklist	12	140
1.12.103	Test and diagnose drone after 100 hours of flying for preventive maintenance		141
1.12.104	Test and diagnose drone after 500 hours of flying		142
1.12.105	Knowledge about drone troubleshooting check list like Equipment check, System reset, calibration, Motor Troubleshooting, Gimbal rotation, Battery Maintenance, and RF Signal and hardware		143
1.12.106	Diagnose the common drone problem like GPS signals are blocked, Decreased battery life, Wrong direction during flight, Flight Planning, Mechanical issue and Firmware issue		144
1.12.107	Inspect drone before and after each flight		145
1.12.108	First time drone hardware assembly and test		146
1.12.109	Test, locate the fault and repair a wiring of drone		149
1.12.110	Check bent or cracked on legs and feet of the drone		150
1.12.111	Demonstration drone wiring connections with different parts		151
1.12.112	Perform takeoff /Landing operation and identify faults in system		153

LEARNING / ASSESSABLE OUTCOME

On completion of this book you shall be able to

S.No.	Learning Outcome	Ref. Ex.No.
1	Identify & select different types of drones, drone rules and regulations, drone applications, and important safety precautions. (Mapped NOS: ELE/N7308)	1.1.01 - 1.1.10
2	Identify & select different drone's mechanical parts, aerodynamics of wings, propellers and disassembly and reassembly of common drone platform with flying practices. (Mapped NOS: ELE/N7308)	1.2.11 - 1.2.20
3	Identify and test various electronic SMD components using proper measuring instruments and Identify, place, solder and de-solder and different SMD discrete components and ICs package with due care and following safety norms using proper tools/setup. (Mapped NOS: ELE/N7308)	1.3.21 - 1.3.26
4	Measure different type electrical parameters and record the data related with drone hardware. (Mapped NOS: ELE/N7005)	1.4.27 - 1.4.34
5	Identification of different type of batteries, battery specifications and their charging techniques used in drone. (Mapped NOS: ELE/N9401)	1.5.35 - 1.5.42
6	Test different sensors, their characteristics and repair which are commonly used in different drones. (Mapped NOS: ELE/N7308)	1.6.43 - 1.6.52
7	Identify, select and test hardware assembly, driver for BLDC motors. (Mapped NOS: ELE/N9402)	1.7.53 - 1.7.60
8	Inspect, test and execute GPS navigation and telemetry module, different RF blocks and antennas used in RF transmitter and receiver. (Mapped NOS: ELE/N7308)	1.8.61 - 1.8.69
9	Test and troubleshoot Flight Controller Board (FCB), Electronic Speed Controller (ESC) and its associated peripherals. (Mapped NOS: ELE/N9403)	1.9.70 - 1.9.82
10	Calibrate and troubleshoot drone gimbal and drone payload. (Mapped NOS: ELE/N9404)	1.10.83-1.10.90
11	Identify and resolve common error messages and corrections by software debugging. (Mapped NOS: ELE/N9405)	1.11.91-1.11.101
12	Inspect, test and execute primary and secondary servicing with trouble shoot malfunctioning, and repair issues discovered. (Mapped NOS: ELE/N7005)	1.12.102 - 1.12.112

SYLLABUS

Duration	Reference Learning outcome	Professional Skills (Trade Practical) With Indicative Hours	Professional Knowledge (Trade Theory)
Professional Skill 42 Hrs; Professional Knowledge 12 Hrs	Identify & select different types of drones, drone rules and regulations, drone applications, and important safety precautions. (Mapped NOS: ELE/N7308)	<ol style="list-style-type: none"> 1 Visit to various sections of the institute and identify location of various installations. 2 Identify safety signs for danger, warning, caution & personal safety message. 3 Practice Use of Personal Protective Equipment (PPE). 4 Practice elementary first aid. 5 Practice Preventive measures for electrical accidents & steps to be taken in such accidents. 6 Practice Use of Fire Extinguishers. 	Familiarization with the working of Industrial Training Institute system. Importance of safety and precautions to be taken in the industry/ shop floor. Introduction to PPEs. Introduction to First Aid. Importance of housekeeping & good shop floor practices.
Professional Skill 63 Hrs; Professional Knowledge 18 Hrs	Identify & select different drone's mechanical parts, aerodynamics of wings, propellers and disassembly and reassembly of common drone platform with flying practices. (Mapped NOS: ELE/N7308)	<ol style="list-style-type: none"> 7 Identify Different types of Drones. 8 Select basic components. 9 Apply principles of flight to Drones. 10 Identify & prepare specific Flight Planning Procedures for specific drone flights. 	Different types of Drones, Nomenclatures, History of aerial drones, reputation, airframe, configurations, basic components, current/future uses of drones. Occupational Safety & Health: Health, Safety and Environment guidelines, legislations & regulations as applicable.
		<ol style="list-style-type: none"> 11 Identify & select different building blocks of the drone. 12 Test drone's different block functionality & their interconnectivity. 13 Identify various types of body material used in drone. 14 Recognize basic principles of flying like Bernoulli's principle. 15 Identify multi rotor design, various configurations, airframe sizes and their construction. 16 Identify different propeller designs and design using 3D printer. 17 Design and development of Drone's body component using 3D printer and related software 18 Identify type of motor used in drone. 19 Identify & prepare specific flight planning procedures to drone flights. 20 Practice drone flying to check to identify faults in drone. 	Understanding Aerial platforms. Types of drones based on aerial platforms. Types of drones based on body material. Introduction to aerodynamics, history of Flight, Newton's Laws of Motion, Bernoulli's Principle, four forces of Flight three axes of Flight, how they apply to drone Flight. Introduction to 3D printer and its software for designing various types of propellers.

Professional Skill 21 Hrs; Professional Knowledge 06 Hrs	Identify and test various electronic SMD components using proper measuring instruments and Identify, place, solder and de-solder and different SMD discrete components and ICs package with due care and following safety norms using proper tools/setup. (Mapped NOS: ELE/N7308)	21 Identify of different types of SMD Components like resistance, capacitance, diode and inductor. 22 Measure different components values using SMD Technology Kit, Tweezers and DMM. 23 Identify of different types of SMD IC packages. 24 Explore and configure SMD soldering and de-soldering rework station. 25 Practice soldering and de-soldering the SMD components on the PCB. 26 Practice soldering and de-solder various IC's of different packages.	Knowledge about soldering station, soldering tools, soldering iron, soldering wicks, soldering temperature etc. Different types of soldering guns, related to Temperature and wattages, types of tips.
Professional Skill 42 Hrs; Professional Knowledge 12 Hrs.	Measure different type electrical parameters and record the data related with drone hardware. (Mapped NOS: ELE/N7005)	27 Identify the type of electronic instruments. 28 Measure the resistance, Voltage, Current through series and parallel connected networks using multi meter. 29 Measure AC and DC voltage using Digital Multi-meter. 30 Measure AC and DC current using Digital Multi-meter. 31 Measure frequency using Digital Multi-meter. 32 Measure the analog signals like of peak to peak voltage, frequency, time period, and duty cycle using of DSO. 33 Measure the frequency and level of RF signals using of spectrum analyzer. 34 Practice function generator and Arbitrary Waveform Generator.	Introduction of electrical components resistance, capacitance, inductance, diode, and transistor. Introduction of electrical parameters like DC voltage, DC current, AC voltage, AC current, frequency, duty cycle and Introduction to electrical and electronic measuring instruments. Working Principle of multimeter, digital storage oscilloscope, spectrum and waveform generator.
Professional Skill 21 Hrs; Professional Knowledge 06 Hrs.	Identification of different type of batteries, battery specifications and their charging techniques used in drone. (Mapped NOS: ELE/N9401)	35 Identify different type of batteries Li-ion and Li-Po. 36 Record and recognize different battery specifications. 37 Explore different charging techniques to charge batteries. 38 Measure and record different parameters of batteries using Battery management platform. 39 Inspect battery packs faults for bulges or leakage. 40 Identify fault related with chargers such as visible damage, voltage and current.	Introduction of different types of batteries used in drone. Understand different specifications and their significance of batteries. Different charging circuits or batteries, What is battery management system (BMS) and different Building Blocks of BMS.

		<p>41 Measure and record different parameters of charging controller using software.</p> <p>42 Calculate maximum discharge and battery capacities in order calculate flight time.</p>	
Professional Skill 42 Hrs; Professional Knowledge 12Hrs	Test different sensors, their characteristics and repair which are commonly used in different drones. (Mapped NOS: ELE/N7308)	<p>43 Identify and measure condition of drone sensors.</p> <p>44 Explore different converters like V/I, I/V, F/V, V/F.</p> <p>45 Verify frequency response of low pass and high pass filters.</p> <p>46 Test and measure different amplifier functions.</p> <p>47 Measure and record the resistance, voltage, current and frequency of different sensors used in drone.</p> <p>48 Test & measure accelerometers, inertial measurement units, tilt and lidar sensor, gyro sensor.</p> <p>49 Write and upload computer code to FCB to test sensors results.</p> <p>50 Calibrate the compass, Lidar, and gyro sensor.</p> <p>51 Measure and record angular rate, force, and magnetic field through IMU.</p> <p>52 Perform amplification of low power signals using current, power, instrumentation, differential, inverting, non-inverting and buffer amplifier circuits.</p>	<p>Introduction of different sensors used in drone like accelerometers, inertial measurement units, tilt and lidar sensor, gyro sensor. Principle of operation of various sensors used in drone; their roles and characteristics. Selection of appropriate sensor as per requirement.</p> <p>Understanding and importance of signal conditioning like voltage to current, current to voltage, frequency to voltage and voltage to frequency convertor, inverting amplifier, non-inverting amplifier, instrumentation amplifier, differential amplifier, power amplifier, current amplifier. How to calibrate Compass sensor, Lidar Sensor, Gyro sensor. Concept of sensor calibration and using sensors in digital & analog mode.</p>
Professional Skill 42 Hrs; Professional Knowledge 12Hrs	Identify, select and test hardware assembly, driver for BLDC motors. (Mapped NOS: ELE/N9402)	<p>53 Identify different BLDC motors and their specifications</p> <p>54 Inspect and test BLDC Motor driver circuit.</p> <p>55 Measure and record speed-torque characteristics of BLDC Motor.</p> <p>56. Explore driving circuit of DC, BLDC and servo motors.</p> <p>57. Perform running and reversing phenomenon of BLDC Motor.</p> <p>58. Demonstration speed control of BLDC Motor using PWM technique.</p> <p>59. Practice Inverted pendulum balancing using programming technique and PID tuning.</p> <p>60. Measure thrust to weight ratio and payload.</p>	<p>Introduction to different motors like DC, BLDC, servo motors, working, understanding its functioning. Studying BLDC motor using PWM techniques, speed torque characteristics, degree of freedom in drone.</p> <p>Performing mathematical calculations like payload calculation, speed control techniques, thrust to weight ratio. Introduction of Inverted Pendulum and PID control. PWM Duty operation and Motor control by Encoder counter.</p>

Professional Skill 21 Hrs; Professional Knowledge 06 Hrs	Inspect, test and execute GPS navigation and telemetry module, different RF blocks and antennas used in RF transmitter and receiver. (Mapped NOS: ELE/N7308)	61. Identify different antennas like patch, helical, and omnidirectional. 62. Record and plot radiation pattern of different antennas. 63. Measure directivity of the antenna. 64. Identify the characteristics of RF circuit blocks like amplifier and filters. 65. Configure and operate 433MHz and 2.4 GHz RC transmitter and receiver. 66. Perform and check connectivity of transmitter and receiver used in drone. 67. Understand GPS and its hardware interfacing with FCB. 68. Connect and Measure and record data of GPS module to determine latitude & longitude. 69. Perform experiment to record, GPGGA, GPGLL, GPGSA, GPGSV, GPRMC and GPVTG values.	Various types of antennas used for drones and their characteristics. Introduction of antenna radiation pattern and directivity. Fundamentals of MIC amplifier and different filter used in RF range. Introduction to RF signals and components used for RC transmitter and receiver. Fundamentals of GPS and concept of navigation systems. Usage of signals from GPS satellites to determine latitude, longitude and altitude
Professional Skill 21 Hrs; Professional Knowledge 06 Hrs	Test and troubleshoot Flight Controller Board (FCB), Electronic Speed Controller (ESC) and its associated peripherals. (Mapped NOS: ELE/N9403)	70. Identify different flight control board and electronic speed control. 71. Perform programming and configure flight control board (FCB). 72. Identify, explore and test interconnectivity of different peripheral with FCB. 73. Establish connection of FCB with motor, GPS, ESC and sensors. 74. Configure, test and record FCB with battery to monitor battery level and perform return to home operation. 75. Perform and carry out drone leveling using IMU sensor. 76. Perform calibration of compass, Lidar, and gyro sensor. 77. Test communication link between FCB and RF transceiver. 78. Write and upload computer code to FCB to test sensors results. 79. Test and record data of motor connectivity with ESC.	Introduction to Flight controller boards and its connectivity with different peripherals like sensors, ESC, GPS, RF module. Introduction Electronic Speed Controller and its connection with motor. ESC configurations using FCB to control speed and direction of motor. Introduction to flight control box and various commands used in it. Configuration techniques for FCB with various motors, GPS etc.

		<p>80. Perform motor rotation using FCB and ESC.</p> <p>81. Test signal flow into drone to test ESC parameters on FCB to check its operation.</p> <p>82. Write and upload computer code to FCB to ESC working.</p>	
Professional Skill 42 Hrs; Professional Knowledge 12Hrs	Calibrate and troubleshoot drone gimbal and drone payload. (Mapped NOS: ELE/N9404)	<p>83 Identify the different types of drones and its application in different areas.</p> <p>84 Identify different features and controls of HD and thermal image camera.</p> <p>85 Test and install Gimbal camera assembly.</p> <p>86 Perform and test Gimbal stabilization</p> <p>87 Perform drone camera control using x, y, and z axes rotation.</p> <p>88 Test and install different cameras on gimbal assembly.</p> <p>89 Practice remote sensing, surveying & mapping, photogrammetry and precision agriculture using HD and thermal image camera.</p> <p>90 Identify and record different application drones and their logged data for investigation.</p>	Fundamental applications of various types of drones. Implementation and handling of HD and thermal image camera for remote sensing and mapping. Introduction to photogrammetry. Image recognition with OpenCV using the drone camera. Fundamental techniques for stabilizing Gimbal.
Professional Skill 42 Hrs; Professional Knowledge 12Hrs	Identify and resolve common error messages and corrections by software debugging. (Mapped NOS: ELE/N9405)	<p>91 Identify bugs in the software program as per the algorithms used and the libraries.</p> <p>92 Resolve common error messages and apply the correct logic.</p> <p>93 Perform firmware configuration and updates.</p> <p>94 Download and Install App / Menu / Planning / Set-up / Flight / Application.</p> <p>95 Demonstration and perform base station software to debugging to get GPS and flight data.</p> <p>96 Perform experiments on software debug tool use to identify coding errors at different stages.</p> <p>97 Setup python and Arduino environment.</p> <p>98 Remote automatic drone operation using Python.</p>	<p>Introduction to software debug tool use to identify coding errors at different stages of development.</p> <p>Introduction to various drone operation using Python and Arduino and setup development environment. Firmware and hardware integration with common errors and their solutions.</p> <p>Introduction to software debugging tools and how to identify cause of coding errors. Introduction to ground base station assembly Introduction to preventive measures for drones.</p>

		<p>99 Knowledge and advantage of preventative maintenance of drone.</p> <p>100. Diagnose problems using Log Data / Analyze Data flash Log Data / Remote Communication Log Data / Save and Execute Log Data.</p> <p>101 Upgrade/downgrade drone firmware Identify error message and resolve approach.</p>	
<p>Professional Skill 21 Hrs; Professional Knowledge 06 Hrs</p>	<p>Inspect, test and execute primary and secondary servicing with troubleshoot malfunctioning, and repair issues discovered. (Mapped NOS: ELE/N7005)</p>	<p>102 Perform primary and secondary servicing based upon the checklist.</p> <p>103 Test and diagnose drone after 100 hours of flying for preventive maintenance.</p> <p>104 Test and diagnose drone after 500 hours of flying.</p> <p>105 Knowledge about drone troubleshooting check list like Equipment check, System reset, calibration, Motor Troubleshooting, Gimbal rotation, Battery Maintenance, and RF Signal and hardware.</p> <p>106 Diagnose the common drone problem like GPS signals are blocked , Decreased battery life, Wrong direction during flight, Flight Planning, Mechanical issue, and Firmware issue.</p> <p>107 Inspect drone before and after each flight.</p> <p>108 First time drone hardware assembly and test. (03 hrs.)</p> <p>109 Test, locate the fault and repair a wiring of drone.</p> <p>110 Check bent or cracked on legs and feet of the drone.</p> <p>111 Demonstration drone wiring connections with different parts.</p> <p>112 Perform takeoff/Landing operation and identify faults in system.</p>	<p>Fundamentals of primary and secondary services. Basics of Gimbal handling and its maintenance. Fundamentals of handling errors rise from GPS. Introduction to battery life maintenance, flight path monitoring. Studying throttle control by moving in either direction. Concept of Visual Inspection and Why Is It Important. Understand the various checks to be carried out to ensure the alignment of control surfaces..</p>

Visit to various sections of the institute and identify location of various installations

Objectives: At the end of this exercise you shall be able to

- visit the various sections/trade in your ITI and draw the layout of your ITI
- record the telephone numbers of the ITI office, hospitals, police station and fire station
- draw the layout of your section
- identify the locations that have electrical installations.

PROCEDURE

TASK 1: Visit various sections of the ITI and draw the layout of your ITI

Instructor will lead the new trainees to various sections of the ITI

- | | |
|---|--|
| <ol style="list-style-type: none"> 1 Visit the various sections in your ITI and identify the sections of the ITI. List the trades and record it in your note book. 2 Collect the information about the staff members in each trade. 3 Identify the location of the ITI with details about the railway and bus stations in the locality and note down the list of bus route numbers which ply near the ITI. | <ol style="list-style-type: none"> 4 Collect the telephone numbers of the ITI office, nearest hospitals, nearest police station and the nearest fire station and record. 5 Draw the layout of your ITI showing various trades. |
|---|--|

Note :A Sample layout of the ITI (Fig 1) is given for your reference. Now draw the new layout of your ITI, with the trades/sections.

Fig 1

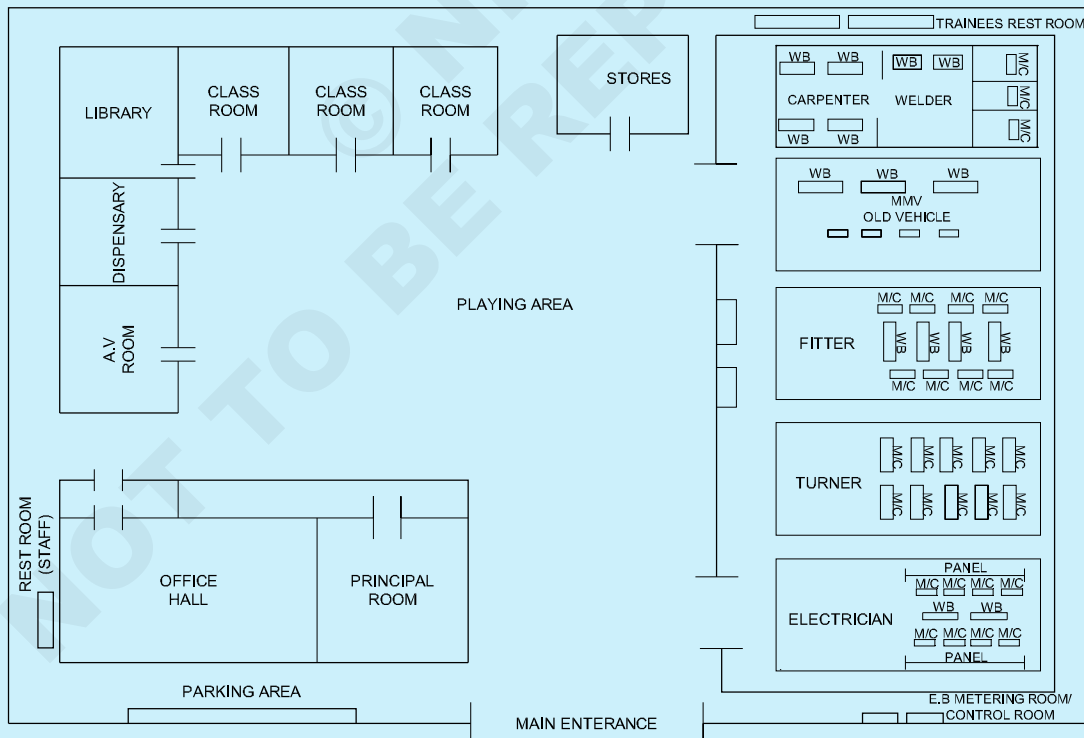

DT20N1101H1

TASK 2: Draw the layout of your section in the ITI

- 1 Draw the plan of your section to a suitable scale in a separate sheet of paper (A4 size).
- 2 Take the length and the breadth measurements of machine foundations, work benches, panels, wiring cubicles, doors, windows, furniture, etc.
- 3 Draw the layout of the machines, work benches, panels and furniture.

The section plan should be in the same scale as in step 1 as per the actual placement of the machine foundations, panels, furniture, work benches etc.

Note : The sample layout of a typical electrician trade section is given for your reference (Fig 2). You have to draw your section's is layout using the sample as reference.

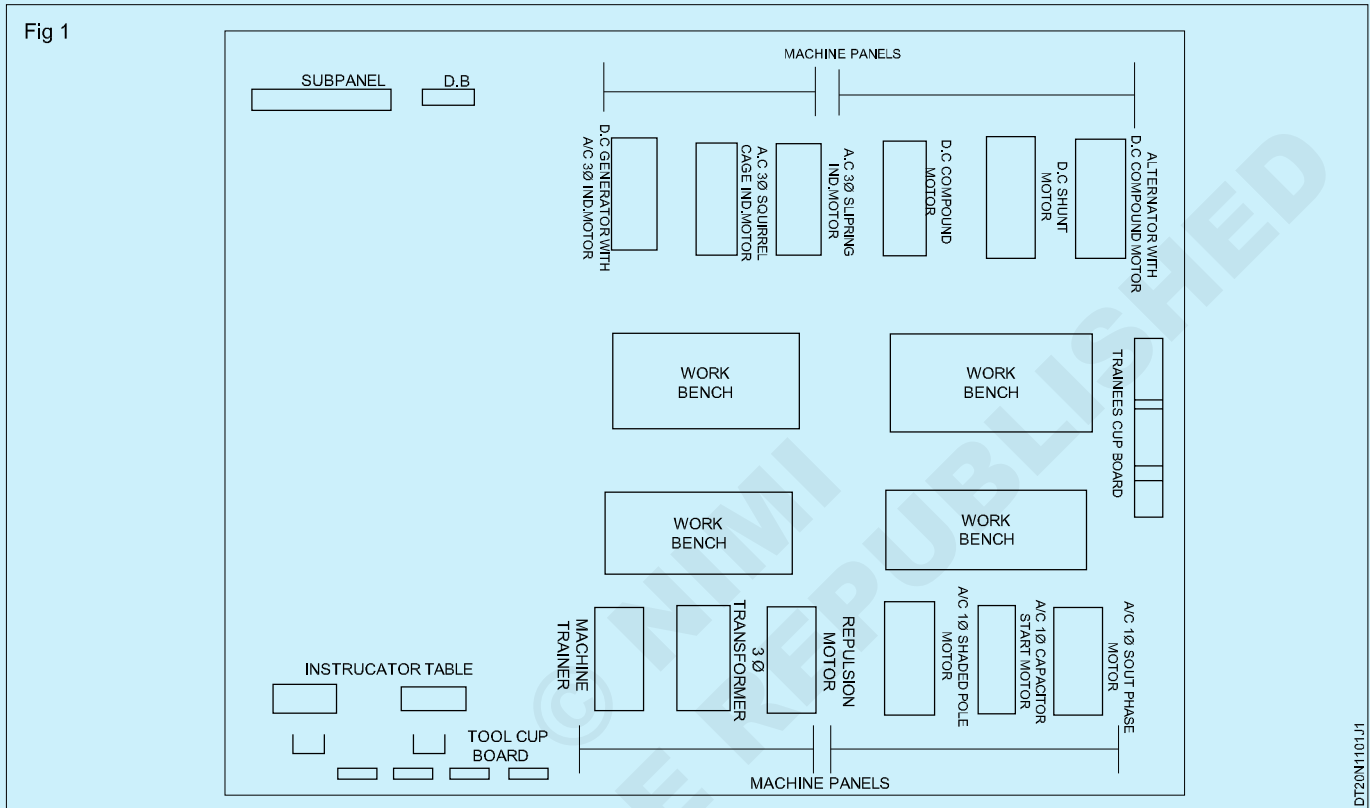

TASK 3: Identify the locations of electrical installations

- 1 Identify the main switch and mark its position in the layout. (Fig 3)
- 2 Identify each of the sub-main switches, the area of control in the section and mark them on the layout.
- 3 Identify 3 or 4 spots in various locations of the electrician sections layout and identify the respective sub-main switches.
- 4 Practice switching 'off' the control switches, depending upon the area of control, imagining that victim are electrocuted in a specific location/spot.

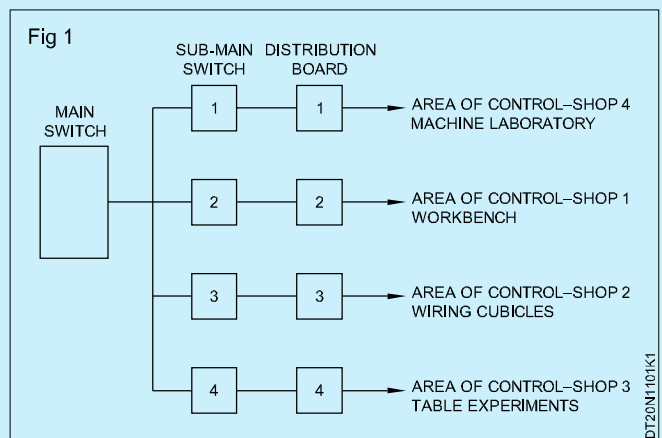

Identify safety symbols and hazards

Objectives: At the end of this exercise you shall be able to

- identify the safety symbols from the chart and their basic categories
- write their meaning and description mentioning where they are used
- identify road safety signs in traffic signals from the chart
- read and interpret different types of occupational hazards from the chart.

Requirements			
Materials			
• Basic safety signs chart	- 1 No.	• Occupational hazards chart	- 1 No.
• Road safety signs and traffic signal chart	- 1 No.		



PROCEDURE





TASK 1: Identify safety symbols and interpret what they mean with the help of their colour and shape

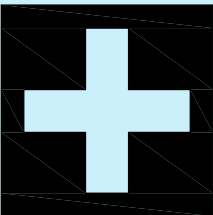
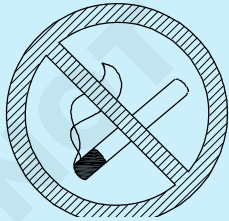

Instructor may provide charts with various safety signs for the road safety signs in traffic signals. Then, explain the categories meaning and colour. Ask the trainees to identify the signs and record it in Table 1.

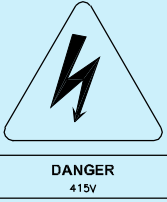
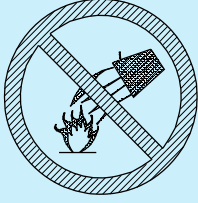
- 1 Identify the signs and their categories from the chart.
- 2 Write the name, categories, meaning and description of each sign and its place of use in Table 1.

Table 1

Sl. No.	Safety signs	Name of the sign and category	Place of use
1			
2			
3			

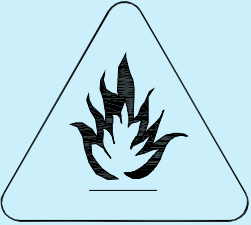
Sl. No.	Safety signs	Name of the sign and category	Place of use
4			
5			
6			
7			
8			

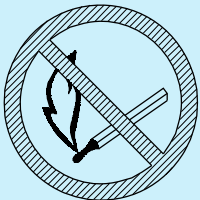
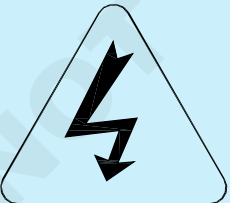
Sl. No.	Safety signs	Name of the sign and category	Place of use
9			
10			
11			
12			
13			

TASK 2 : Identify the road safety signs and traffic signal signs.

Instructor will explain all the road safety signs and traffic signal signs

- 1 Identify the sign and give details of its kind and meaning in Table 2.
- 2 Get it checked by the instructor

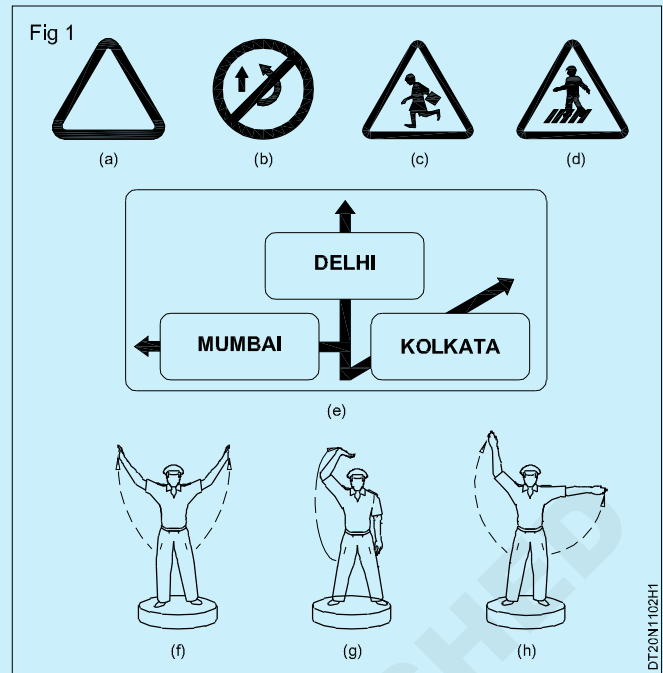

Table 2

Figure Number	Label	Kind of road sign	Name of the signal	Meaning of the sign
1	a			
2	b			
3	c			
4	d			
5	e			
6	f			
7	g			
8	h			

TASK 3 : Read and interpret the different types of personal protective equipment (PPE) from the chart

Instructor may brief the various types of occupational hazards and their causes.

- 1 Identify the occupational hazard matching it to the corresponding situation with the given potential in Table 3.
- 2 Complete the details and get it checked by your instructor.

Table 3

Sl.No.	Source or potential harm	Type of occupational hazard
1	Noise	
2	Explosive	
3	Virus	
4	Sickness	
5	Smoking	
6	Non-control device	
7	No earthing	
8	Poor housekeeping	

© NIMI
NOT TO BE REPUBLISHED

Use of personal protective equipment

Objectives: At the end of this exercise you shall be able to

- read and interpret different types of Personal Protective Equipment (PPE) from the chart (or) real PPE
- identify and name the PPEs corresponding to the type of protection and write their uses.

Requirements
<p>Tools / Equipment</p> <ul style="list-style-type: none"> • Chart showing different types of PPEs - 1 No. • Real PPEs(available in section) - as required.

PROCEDURE



Instructor may arrange the available different types of PPEs in the table or provide the chart showing the PPEs. Instructor may also explain the types of PPEs and their uses, and the hazards for which each type is used.

- 1 Identify the different types of PPEs and write their names with the help of the chart and write in Table 1.
- 2 Write the type of protection and uses in the space provided against each PPE in Table 1.

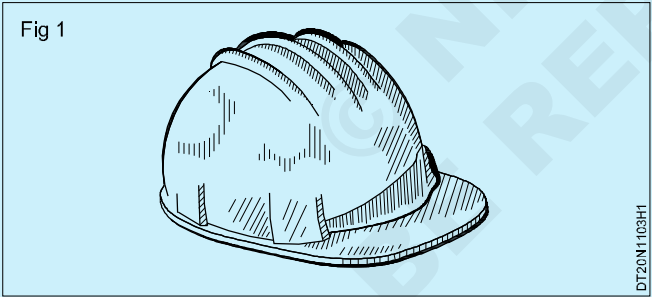
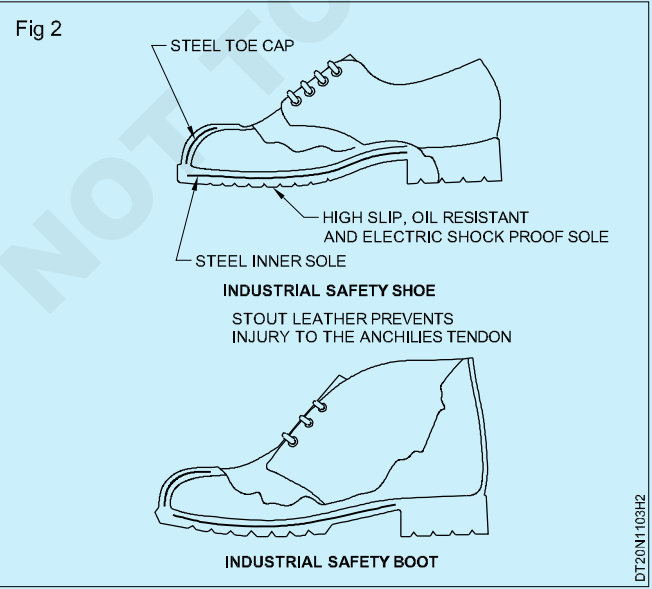
Table 1

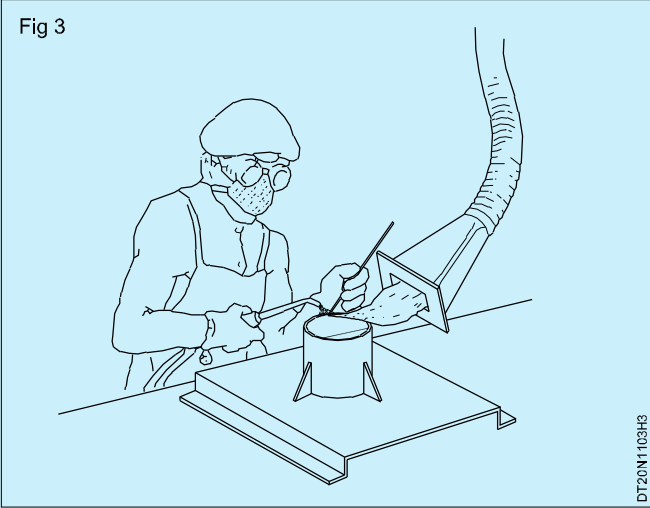
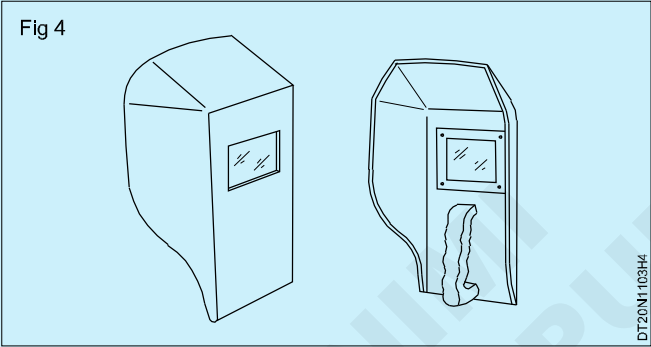
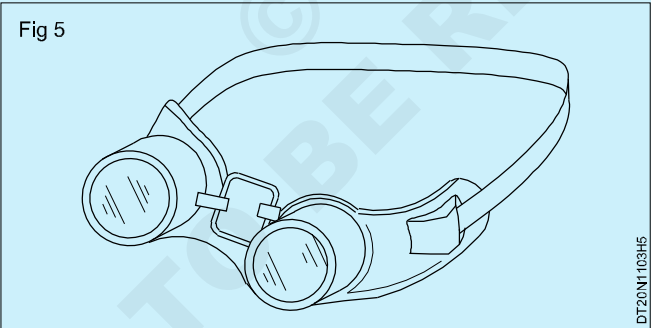
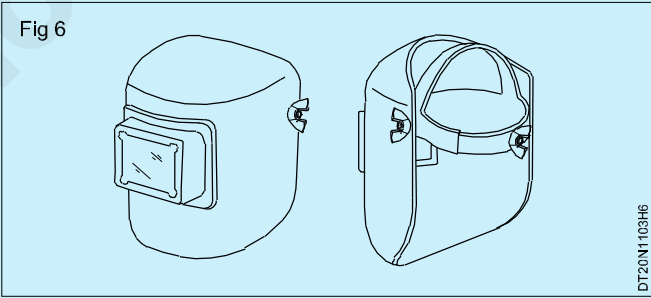
Sl. No.	Sketches	Name of PPE	Type of protection	Uses
1	<p>Fig 1</p> 			
2	<p>Fig 2</p> 			

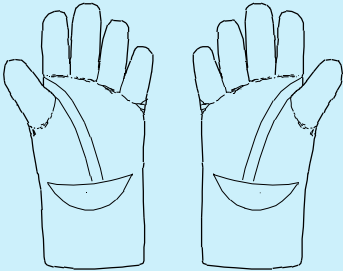
Sl. No.	Sketches	Name of PPE	Type of protection	Uses
3	<p data-bbox="368 192 424 219">Fig 3</p>  <p data-bbox="991 591 1010 685" style="writing-mode: vertical-rl; transform: rotate(180deg);">DT20N1103H3</p>			
4	<p data-bbox="368 754 424 781">Fig 4</p>  <p data-bbox="999 992 1018 1086" style="writing-mode: vertical-rl; transform: rotate(180deg);">DT20N1103H4</p>			
5	<p data-bbox="368 1189 424 1216">Fig 5</p>  <p data-bbox="999 1404 1018 1498" style="writing-mode: vertical-rl; transform: rotate(180deg);">DT20N1103H5</p>			
6	<p data-bbox="368 1626 424 1653">Fig 6</p>  <p data-bbox="999 1807 1018 1901" style="writing-mode: vertical-rl; transform: rotate(180deg);">DT20N1103H6</p>			

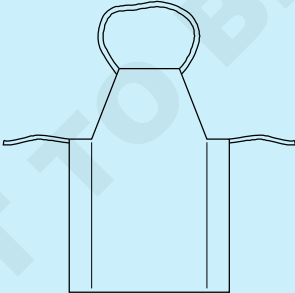
SI. No.	Sketches	Name of PPE	Type of protection	Uses
7	<p data-bbox="288 210 341 237">Fig 7</p>  <p data-bbox="906 421 927 517" style="writing-mode: vertical-rl; transform: rotate(180deg);">RP20N1103H7</p>			
8	<p data-bbox="288 595 341 622">Fig 8</p>  <p data-bbox="906 1137 927 1234" style="writing-mode: vertical-rl; transform: rotate(180deg);">DT20N1103H8</p>			
9	<p data-bbox="288 1290 341 1317">Fig 9</p>  <p data-bbox="906 1541 927 1637" style="writing-mode: vertical-rl; transform: rotate(180deg);">DT20N1103H9</p>			

3 Get it checked by your instructor.

Practice elementary first aid

Objective: At the end of this exercise you shall be able to
• **prepare the victim for elementary first aid.**

Requirements

Equipment/Materials

- Number of Persons (Instructor can divide the trainees into suitable Number of groups.) - 20 Nos.

PROCEDURE

Assumption: For easy manageability, Instructor may divide the trainees into groups and ask each group to perform one method of resuscitation

Prepare the victim before giving first-aid treatment

- 1 Loosen the tight clothing as it may interfere with the victim's breathing. (Fig 1)
- 3 safely bring the victim to the level ground, taking the necessary safety measures. (Fig 3)

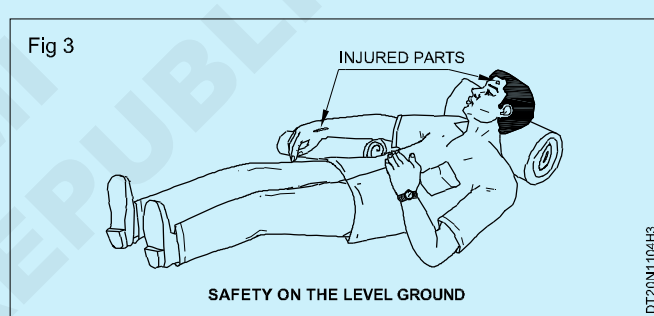

- 2 Remove any foreign material or false teeth from the victim's mouth and keep the victim's mouth open. (Fig 2)

Do not waste too much time in loosening the clothes or trying to open the tightly closed mouth.



- 4 Avoid violent operations to prevent injury of the victim's internal parts.

TASK 2: Prepare the victim for artificial respiration

**Observe the condition of electric shock victim.
If breathing has stopped, try to provide artificial respiration**

- 1 Send word for professional assistance. (If no other person is available, you stay with the victim and help as best as you can.)
- 2 Look for visible injury in the body and decide on the suitable method of artificial respiration.
 - In the case of injury/burns on the chest and/or belly follow the mouth to mouth method.
 - In case the mouth is closed tightly, use Schafer's or Holger-Nelson method.
 - In the case of burn and injury in the back, follow Nelson's method.
- 3 Place the victim in the correct position before giving artificial respiration.

**All actions should be taken immediately.
Delay by even a few seconds may be dangerous.
Take extreme care to prevent injury to the victim's internal organs.**

- 4 Cover the victim with coat, sacks or improvise with your own method. Help to keep the victim's body warm.
- 5 Proceed to perform the suitable artificial respiration method.

© NIMI
NOT TO BE REPUBLISHED

Preventive measures for electrical accidents and practice steps to be taken in such accidents

Objectives: At the end of this exercise, you shall be able to

- practice and follow preventive safety rules to avoid electrical accidents
- rescue the electric shock victim.

Requirements	
Materials	
• Heavy insulated screwdriver 200 mm - 1 No.	• Wooden stool - 1 No.
• Electrical safety chart (or) display - 1 No.	• Ladder - 1 No.
• Gloves - 1 No.	• Safety belt - 1 No.
• Rubber mat - 1 No.	

PROCEDURE

TASK 1: Practice and follow preventive safety rules to avoid electrical accidents

- 1 Do not work on live circuits. If unavoidable use rubber gloves or rubber mats.
- 2 Do not touch bare conductors.
- 3 Stand on a wooden stool or an insulated ladder while repairing live electrical circuits/appliances or replacing fused bulbs.
- 4 Stand on rubber mats while working, operating switch panels, control gears, etc.
- 5 Always use safety belts while working on poles or high-rise points.
- 6 Use screwdrivers with wooden or PVC insulated handle when working on electrical circuits.
- 7 Replace (or) remove fuses only after switching off the circuit switches.
- 8 Open the main switch and make the circuit dead.
- 9 Do not stretch your hands towards any moving part of the rotating machine and around moving shafts.
- 10 Always use earth connection for all electrical appliances along with 3-pin sockets and plugs.
- 11 Do not connect earthing to the water supply electrical lines.
- 12 Do not use water on electrical equipment.
- 13 Discharge static voltage in HV lines/equipment and capacitors before working on them.
- 14 Keep the workshop floor clean and tools in good condition.

TASK 2 : Rescue the electric shock victim

- 1 Proceed with treatment as early as possible without panic or becoming emotional.
- 2 Switch OFF the power or remove the plug or wrench the cable free.
- 3 Move the victim from contact with the live conductor by using dry non-conducting materials like wooden bars. (Fig 1 & 2)

Avoid direct contact with the victim. Wrap your hands with dry material if rubber gloves are not available. If you are uninsulated, do not touch the victim with your bare hands.

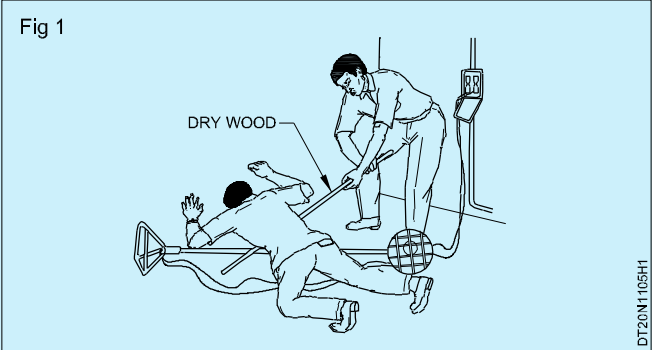

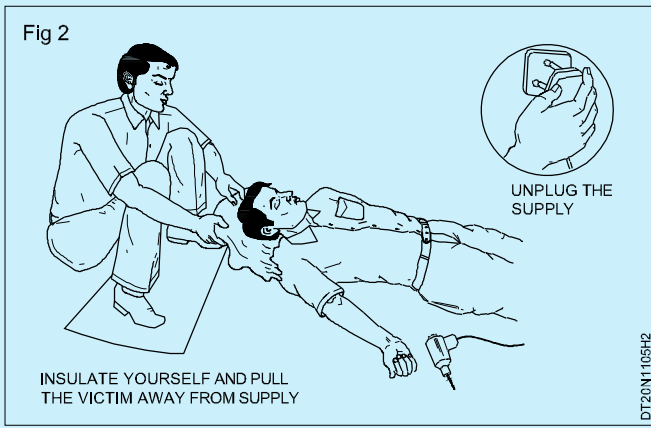

4 Keep the patient warm and at mental rest.

Ensure that there is good air circulation. Seek help to shift the patient to a safer place. If the victim is aloft, take steps to prevent him from falling.

5 Loosen the clothing near the neck, chest and waist and place the victim in a relaxed position, if the victim is unconscious.

6 Keep the victim warm and comfortable. (Fig 3)

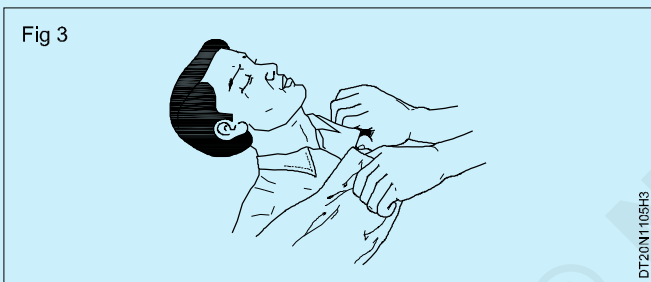

7 Send someone to call the doctor, in case of electric burns.

If the victim has electrical burns due to shock, it may be very painful and is dangerous. If a large area of the body is burnt do not give treatment. Give first-aid as given in step 8

- 8 Cover the burnt area with pure running water.
- 9 Clean the burnt area using a clean cloth/cotton.
- 10 Send someone to call the doctor immediately.

In case of severe bleeding

- 11 Lay the patient flat.
- 12 Raise the injured part above the body level. (If possible)
- 13 Apply pressure on the wound ,as long as necessary, to stop the bleeding. (Fig 4)

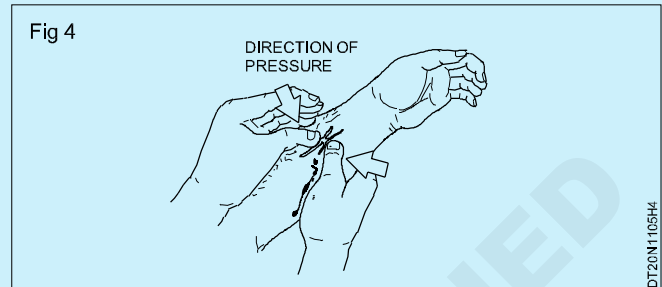

14 cover the injured area with a clean pad and bandage firmly, if it is a large wound. (Fig 5)

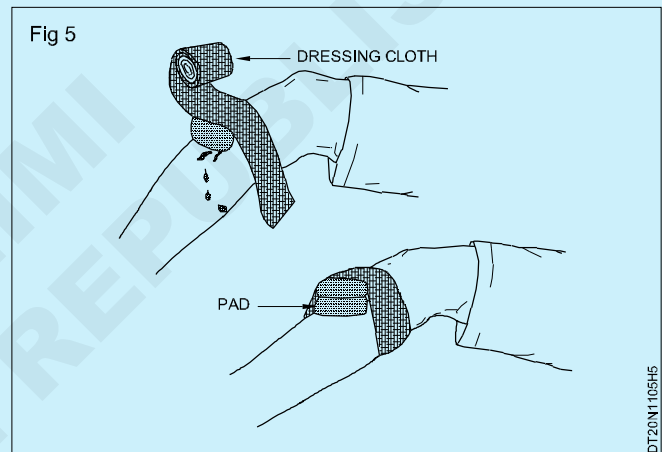

If bleeding is severe, use more than one dressing.

15 initiate right methods of artificial respiration, if the person is unconscious

Use of fire extinguishers

- Objectives:** At the end of this exercise you shall be able to
- select fire extinguishers according to the type of the fire
 - operate the fire extinguisher
 - extinguish the fire.

Requirements			
Equipment/Machines			
• Fire extinguishers-CO ₂	- 1 No.	• Cell phone	- 1 No.
• Scissors 100mm	- 1 No.		

PROCEDURE

- 1 Alert people in the surrounding area by shouting fire, fire when you see fire (Fig 1a & b).
- 2 Inform fire service or arrange to inform them immediately (Fig 1c).
- 3 Open the emergency exit and ask the people inside the area to go away (Fig 1d).
- 4 Switch "OFF" all electrical power supply.
- 5 Analyze to identify the type of fire. Refer Table1.
- 6 Assume that is it type D fire (Electrical fire).

Do not allow people to go near the fire.

Fig 1

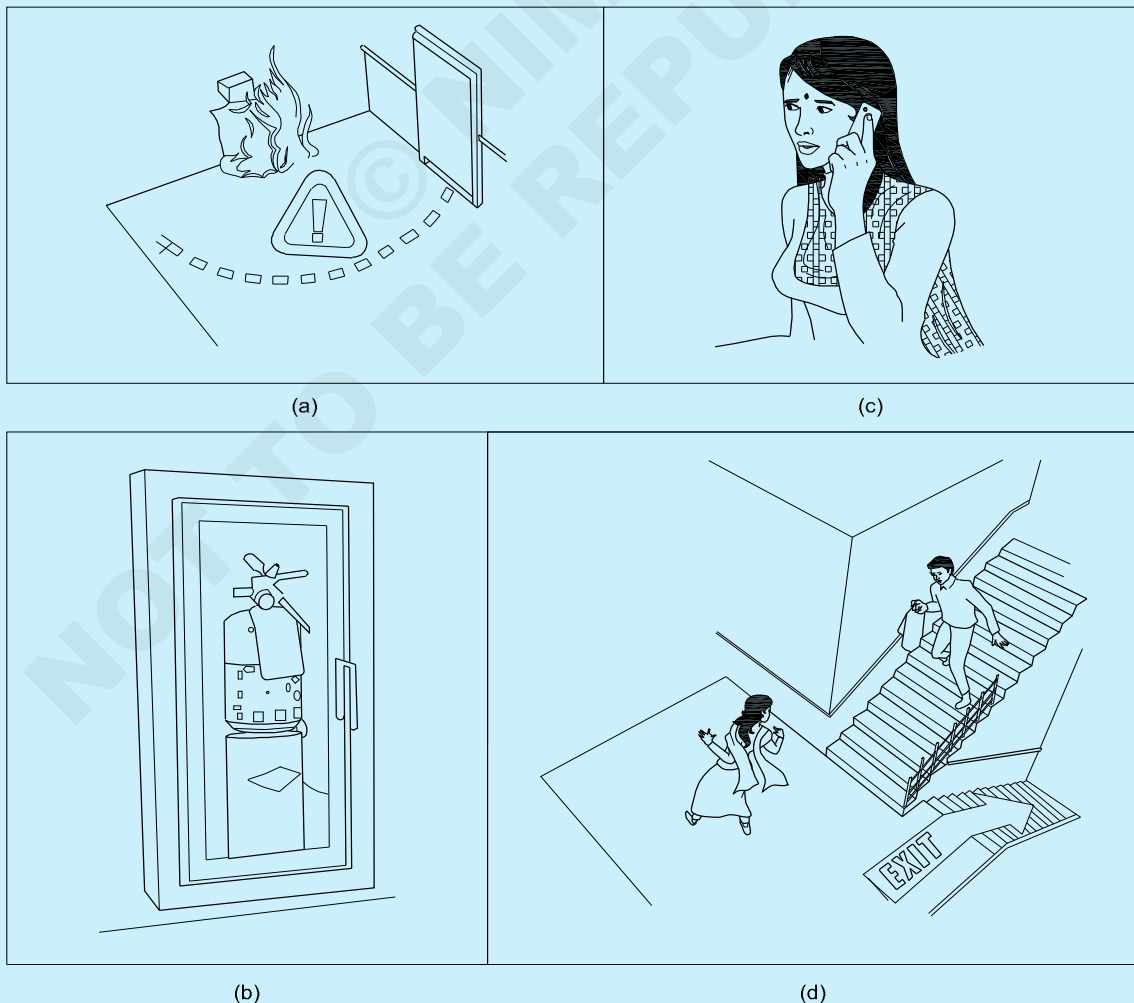

DT20N1106H1

Table 1

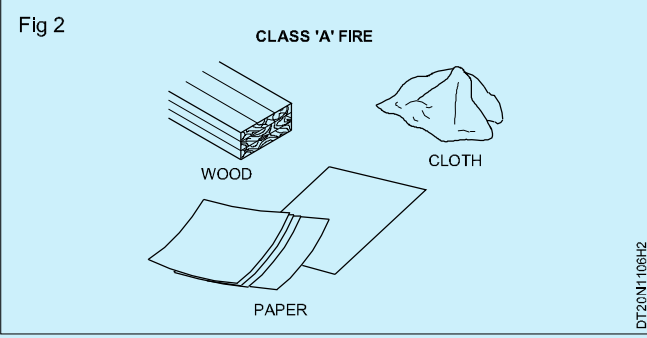
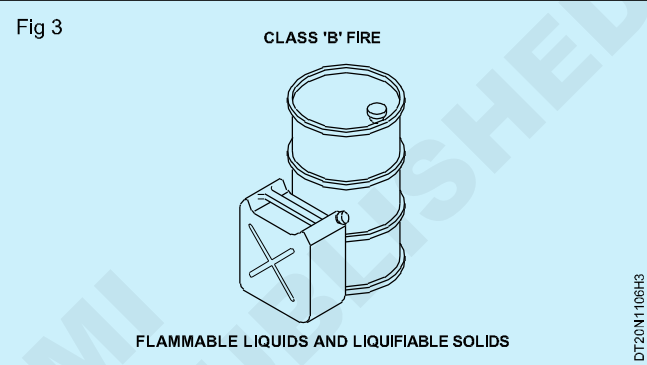
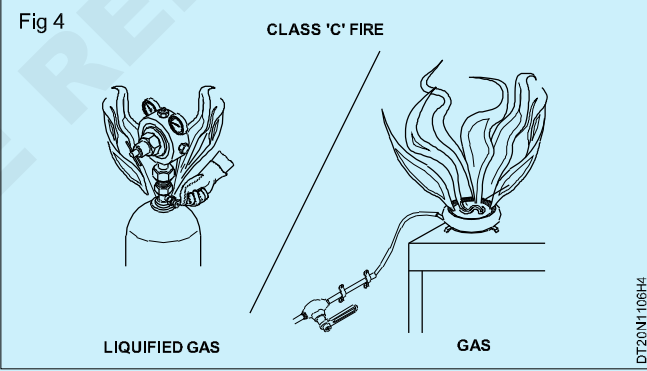
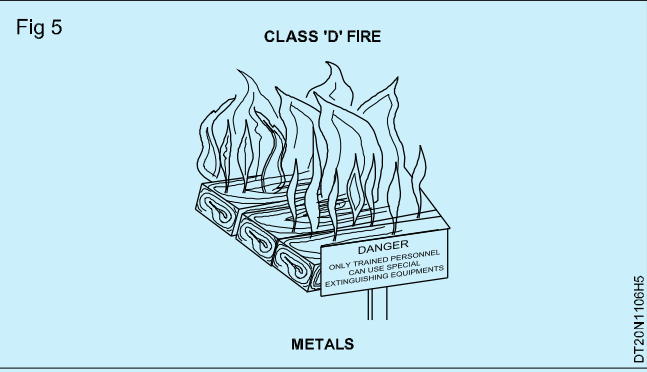
<p>Class 'A': Wood, paper, cloth, solid material</p>	<p>Fig 2</p> <p>CLASS 'A' FIRE</p>  <p>WOOD</p> <p>CLOTH</p> <p>PAPER</p> <p>DT20N1106H2</p>
<p>Class 'B': Oil-based fire (grease, gasoline, oil) and liquefiable solids</p>	<p>Fig 3</p> <p>CLASS 'B' FIRE</p>  <p>FLAMMABLE LIQUIDS AND LIQUIFIABLE SOLIDS</p> <p>DT20N1106H3</p>
<p>Class 'C': Gas and liquefied gases</p>	<p>Fig 4</p> <p>CLASS 'C' FIRE</p>  <p>LIQUIFIED GAS</p> <p>GAS</p> <p>DT20N1106H4</p>
<p>Class 'D': Metals and electrical equipment</p>	<p>Fig 5</p> <p>CLASS 'D' FIRE</p>  <p>DANGER ONLY TRAINED PERSONNEL CAN USE SPECIAL EXTINGUISHING EQUIPMENTS</p> <p>METALS</p> <p>DT20N1106H5</p>

- 7 Select CO₂ (carbon dioxide) fire extinguisher.
- 8 Locate and take the CO₂ fire extinguisher. Check for its expiry date.
- 9 Break the seal. (Fig 6)

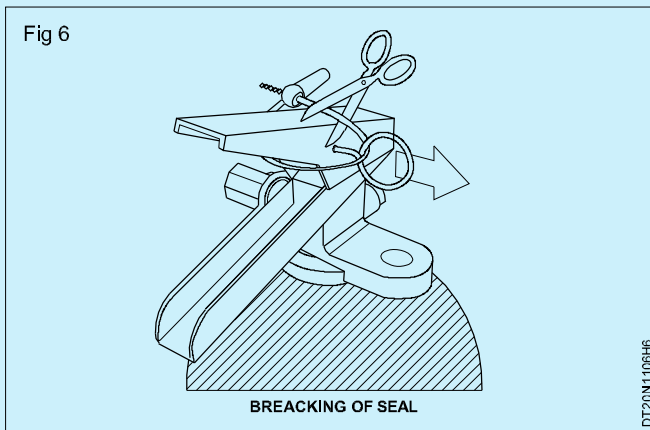

- 10 Pull the safety pin from the handle. (Fig 7) (the Pin is located at the top of the fire extinguisher.) (Fig 7)

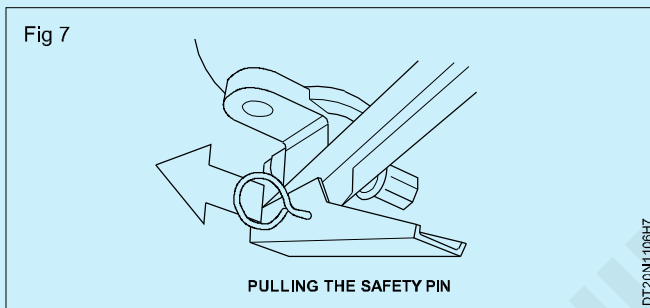

- 11 Aim the extinguisher nozzle or hose at the base of the fire. (This will remove the source of the fuel fire.) (Fig 8)

Keep your self low

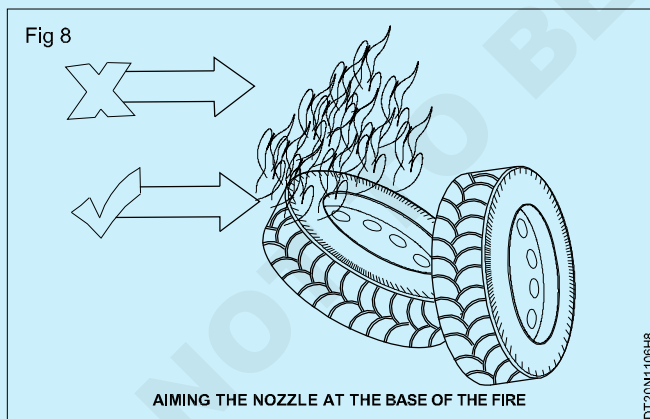

- 12 Slowly squeeze the handle lever to discharge the agent. (Fig 8)
- 13 Sweep from side to side approximately 15 cm over the fuel fire until the fire is put off. (Fig 9)

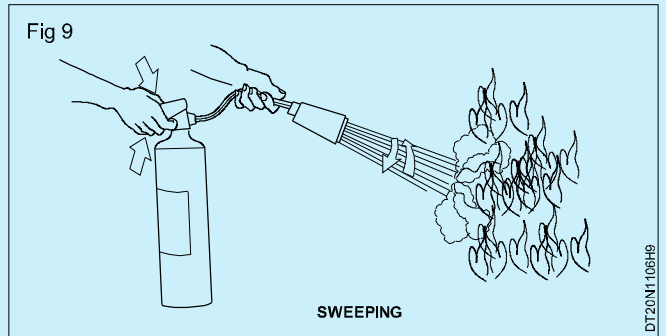

Fire extinguishers are manufactured for use from a distance.

Caution

- While putting off fire, the fire may flare up.
- Do not panic so long as it is being put off promptly
- If the fire does not respond well even after you have used the fire extinguisher, move away from the fire point.
- Do not attempt to put out a fire when it emits toxic smoke. Leave it to the professionals.
- Remember that your life is more important than the property. So do not take risks.

In order to remember the simple operation of fire extinguisher, remember P.A.S.S.

This will help to use the fire extinguisher.

P for pull

A for aim

S for squeeze

S for sweep

Identify Different types of Drone

Objectives : At the end of this exercise you shall be able to

- **determine different types of Drones**
- **write the names of type of drone in table.**

PROCEDURE

TASK 1: Determine Different types of Drones.

- 1 Identify the different types of drones and write their names with the help of the diagram in Table 1.
- 2 Get it checked by the instructor.

The instructor shall display the different types of Drones or diagram and explain how to identify Drones ask the trainees to note down the type of Drones in the Table 1.

Table 1

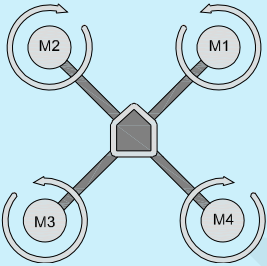
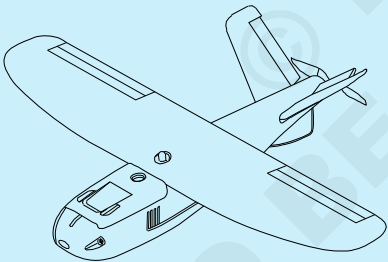
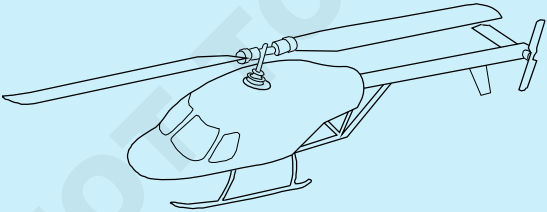
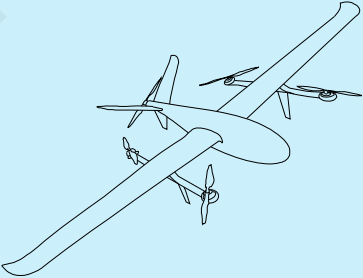
S.No.	Picture	Type
1		
2		
3		
4		

TASK 2: Determine Different types of Drones categories are specified by the DGCA Civil RPA in included with MTOW (including payload) as shown below:

- 1 Visuals the drone from the diagram.
- 2 Identify drone used for different types of drones.
- 3 Write the name of the drone and the corresponding type of drone in table 2.

Instructor may brief the various types of drones and their types.

Table 2

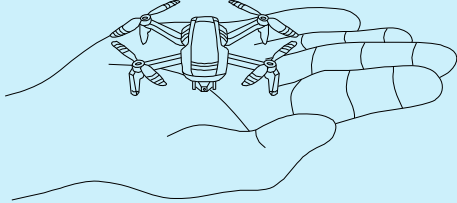
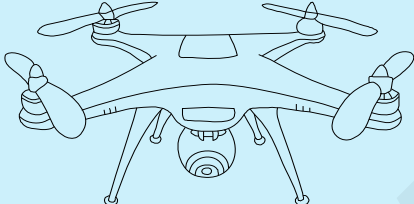
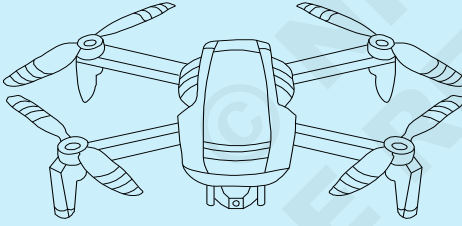
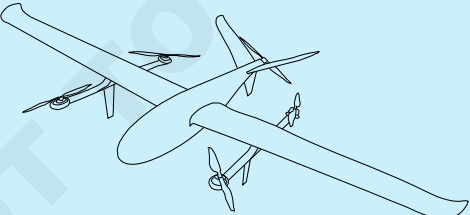
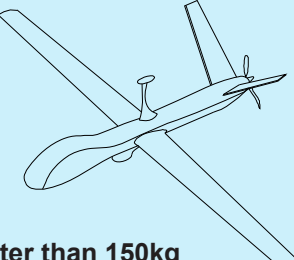
S.No.	Picture	Type
1	 Less than or equal to 250 grams	
2	 Greater than 250 grams and less than or equal to 2kg	
3	 Greater than 2 kg and less than or equal to 25 kg	
4	 Greater than 25 kg and less than or equal to 150kg	
5	 Greater than 150kg	

Select basic components

Objectives: At the end of this lesson you shall be able to

- select the proper type of Drones basic components
- record the specification of the drone in table.

Requirements			
Materials			
• Electronic Speed Controllers (ESC)	-1 No	• Drone Frame	- 1 No
• BLDC Brushless Motor	- 1 No	• Drone Battery	- 1 No
• Propeller	- 1 No	• Balance Charger/Discharger	-1 No
• Flight Controller	- 1 No	• Connector	- 1 No
• Transmitter and Receiver	- 1 No	• Landing Gear	- 1 No

PROCEDURE

Select the proper drone basic components

- 1 Read proper components for drone from table 17.1.
- 2 Identify and select basic components
- 3 Write the Specification and quantity of each selected components.
- 4 Fill up and get it checked by your instructor.

Instructor provides different basic components.

Table 1

S.NO	Components	Specification	Quantity
1	Drone Frame		
2	BLDC Brushless Motor		
3	Electronic Speed Con-trollers (ESC)		
4	Flight Controller		
5	Landing Gear		
6	Transmitter		
7	Propellers		
8	Receiver		
9	Drone Battery		
10	Battery Charger/Discharger Bal-ance		
11	Connector (Male - Fe-male)		

Apply principles of flight to Drones

Objective: At the end of this lesson you shall be able to

- **principal of Aerodynamic.**

PROCEDURE

The principles of flight are the aerodynamics dealing with the motion of air and forces acting on an aircraft

- 1 Lift is the most apparent force, as its what we think of as giving an aircraft the ability to fly
- 2 Thrust provides a method with which to move the aircraft
- 3 Drag, and weight are those forces that act upon all aircraft in flight
- 4 Understanding how these forces work together and knowing how to control them with the use of power and flight controls are essential to flight

© NIMI
NOT TO BE REPUBLISHED

Drone Technician - Safety Rules and Regulations**Identify & prepare specific Flight Planning Procedures for specific drone flights**

Objective: At the end of this exercise you shall be able to

- **procedures for Flight Planning.**

PROCEDURE**Procedures for Identify & prepare specific Flight Planning.**

- 1 Firstly, Instructor should comply to trainee with the provisions contained in ENR 1.10 of AIP-India. 13.6.11.2
- 2 Explain the ICAO model flight plan format.
- 3 Note down UIN of the RPA which is used as aircraft identification for the flight plan.
- 4 Get the Additional information pertaining to RPA flights may be included under Item 18 of the flight plan. 13.6.11.3.
- 5 Fill the following additional information pertaining to RPA flights should be included in the flight plan:
 - a Category of RPAS
 - b Type of Operation (VLOS / BVLOS / BRLOS)
 - c Name of Operator and UAOP number
 - d Contact number of Remote Pilot
 - e Purpose of Flight
 - f Payload information
 - g Autonomous Flight Termination / Return Home capability
 - h Geo-fencing capability
 - i Detect and Avoid capability.
- 6 Get the details checked by the instructor.

Instructor should explain about the ICAO model flight plan format.

Prepare Specific Flight Planning for specific drone flights

Drone Technician - Identify & Select Different Types of Drones**Identify & select different building blocks of the drone**

Objectives : At the end of this exercise you shall be able to

- identify different building blocks of the drone
- select proper building blocks of the drone for specific uses.

Requirements**Material**

- Unassembled drone - 1 No.

PROCEDURE**Identification of different building blocks of the drone**

- 1 Select and identify the different components of drone in the image and note down the names of spare parts of drone
- 2 Refer to the below image, identify the type of different building blocks of the drone and record them. (Fig 1)
- 3 Get the work checked by the instructor.

Instructor Explain about the spare parts of drone

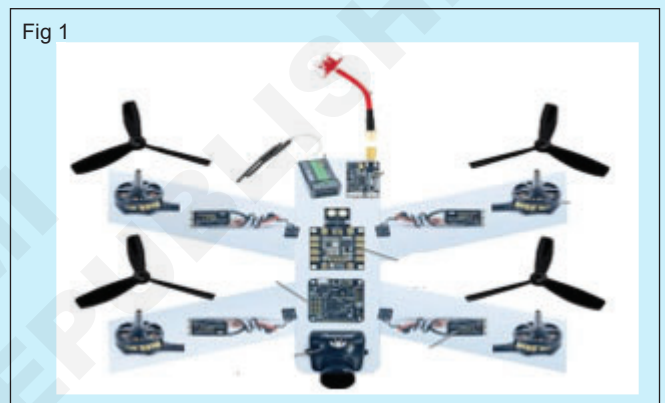

Test drone's different block functionality & their interconnectivity

- Objectives :** At the end of this exercise you shall be able to
- test and identify the interconnectivity of a drone's different block
 - understand drone's different block functionality.

Requirements
Material <ul style="list-style-type: none">• Unassembled drone - as per required.

PROCEDURE

Testing of the drone's different block functionality & their interconnectivity

- 1 Collect all the components required and check them for good working condition using multimeter.
- 2 Assemble the different block of drone as shown in Fig 1.
- 3 Get the assembled block checked by the instructor
- 4 Connect the battery to assembled block and check their functionality & their interconnectivity.
- 5 Fill the details in the table 1

Instructor should explain about the function of each spare part of drone and their wire connections.

Table 1

SI.No.	Name of the connector	No. of wires	Type of connector	Connected to which section/device	Remark
1					
2					
3					
4					
5					
6					

- 6 Get the work checked by the instructor.

Drone Technician - Identify & Select Different Types of Drones

Identify various types of body material used in drone

Objective: At the end of this exercise you shall be able to

- identify different body material used in drone.

Requirements
<p>Material</p> <ul style="list-style-type: none"> • Different Material Frame - as per required.

PROCEDURE

Identify different body material used in drone

- 1 Pick any one of the materials
- 2 Identify the name of the material.
- 3 Record the name and its application in the TABLE 1.
- 4 Repeat above steps for all other materials and write in table 1.

Table 1

S. No.	Materials Name	Specification
1		
2		
3		
4		

Recognize basic principles of flying like Bernoulli's Principle

Objective: At the end of this exercise you shall be able to
 • **statement of Bernoulli's Principle.**

PROCEDURE

Bernoulli's Principle

Instructor should explain the definition of Bernoulli's Principle

- 1 Write the formula for Bernoulli's principle.

Space for writing Formula

- 2 Get the work checked by the instructor

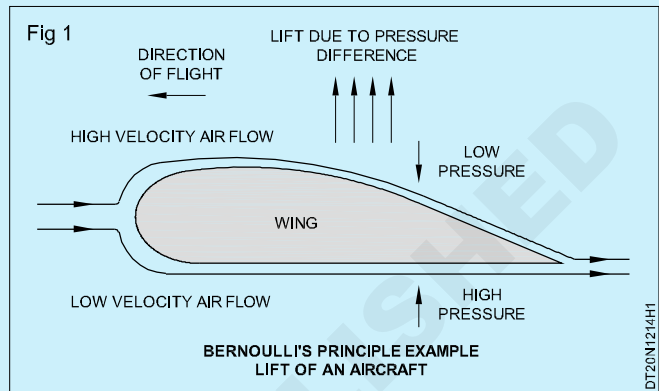

Identify multi rotor design, various configurations, airframe sizes and their construction

Objectives: At the end of this exercise you shall be able to

- identify types of various configurations
- identify airframe sizes
- construction materials.

PROCEDURE

TASK 1: Determine multi rotor design

- 1 Visuals the multi rotor designs from the diagram shown in table
- 2 Identify type of the multi rotor design.
- 3 Write the name of the multi rotor design and the corresponding type of it in table 1.
- 4 Get it checked by the instructor

The instructor shall display the various configurations of multi rotor design and explain how to identify it, ask the trainees to note down the type of multi rotor design various configurations in the Table 1.

Table 1

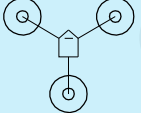
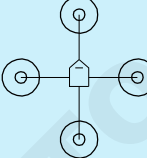
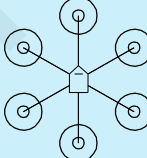
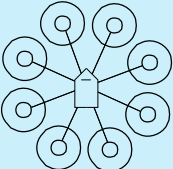
S.No	Multi Rotor Design	Number of Motors	Type
1			
2			
3			
4			
5			

TASK 2: Various Configurations

1 Visuals the drone from the diagram.

2 Identify drone used for different types of drones.

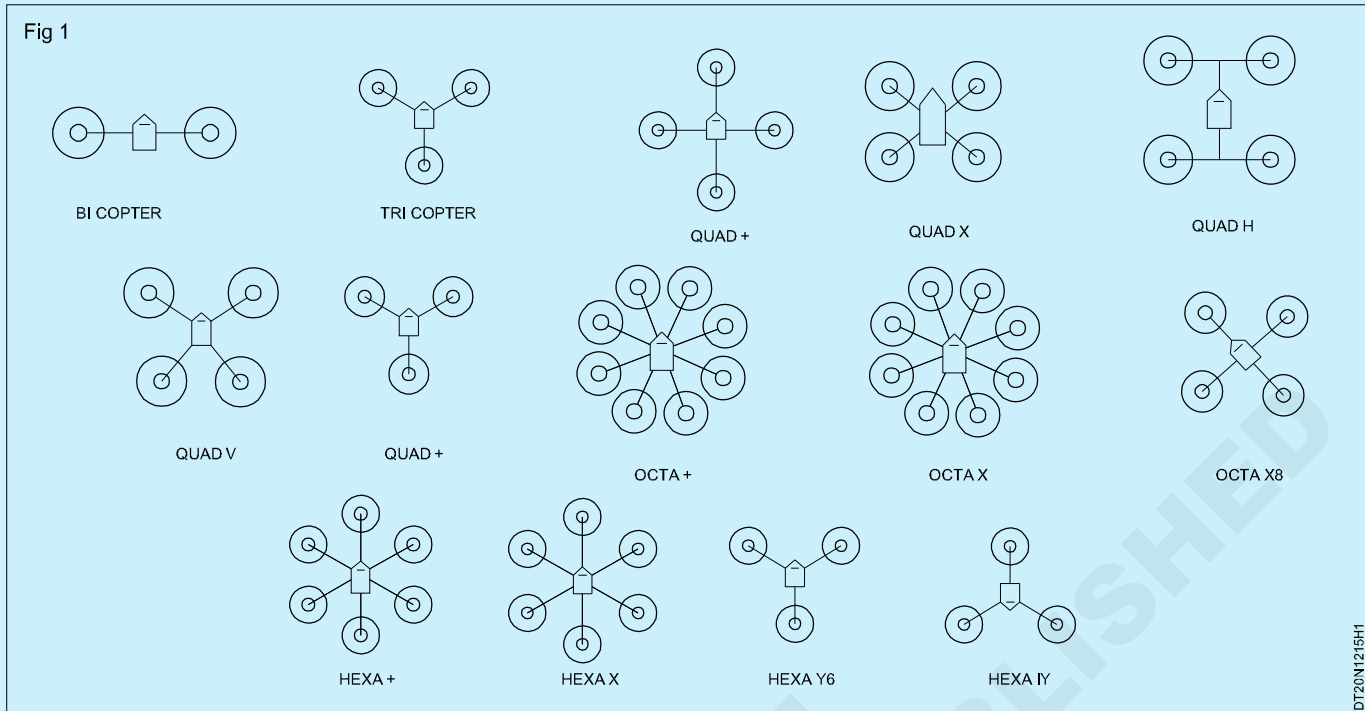

3 Write the name of the drone and the corresponding type of drone in table 2.

Table 2

S.No	Multi Rotor Configurations	Number of Motors	Type
1			
2			
3			
4			
5			

TASK 3: Production Airframe Dimensions

1 The frame is the supportive basic part for all mounted components.

3 For airframe the main dimension is diagonal distance between two motors.

2 Frame depends on the overall design & configuration part of the drone.

4 Trainee should measure the diagonal distance between two motors and write in the table

Table 3

S.No	Airframe Type	Dimensions
1		
2		
3		
4		
5		

TASK 4: Identification of Construction Materials of airframe.

1 Collect all the different construction material from instructor

2 Find out the material and write in the table 4.

3 Get the work checked by the instructor

TABLE 4

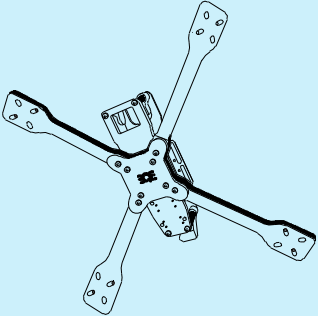
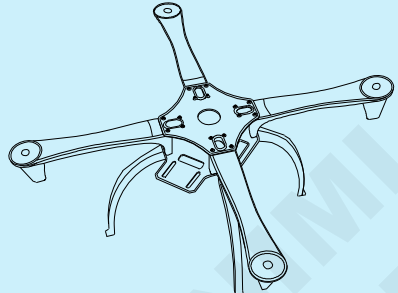
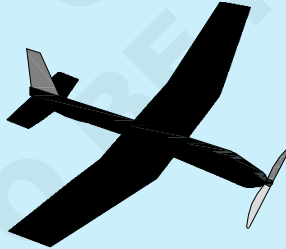
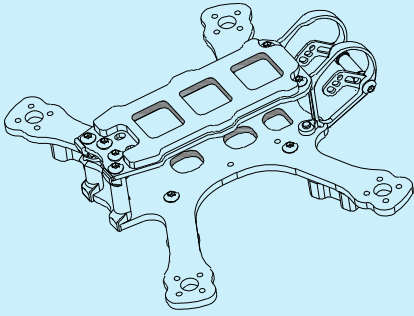
S.No.	Air Frame	Materials
1		
2		
3		
4		

Identify different propeller designs and design using 3D printer

Objectives: At the end of this exercise you shall be able to

- identify propeller designs
- develop propeller using 3D printer.

Requirements	
Material	
• Propeller	-1No.
• 3D printer	-1No.

PROCEDURE

TASK 1: Determine different propeller designs

- 1 Visuals the propeller from the diagram.
- 2 Identify propeller used for different types of drones.
- 3 Write the name of the propeller and the corresponding type of propeller in table 1.

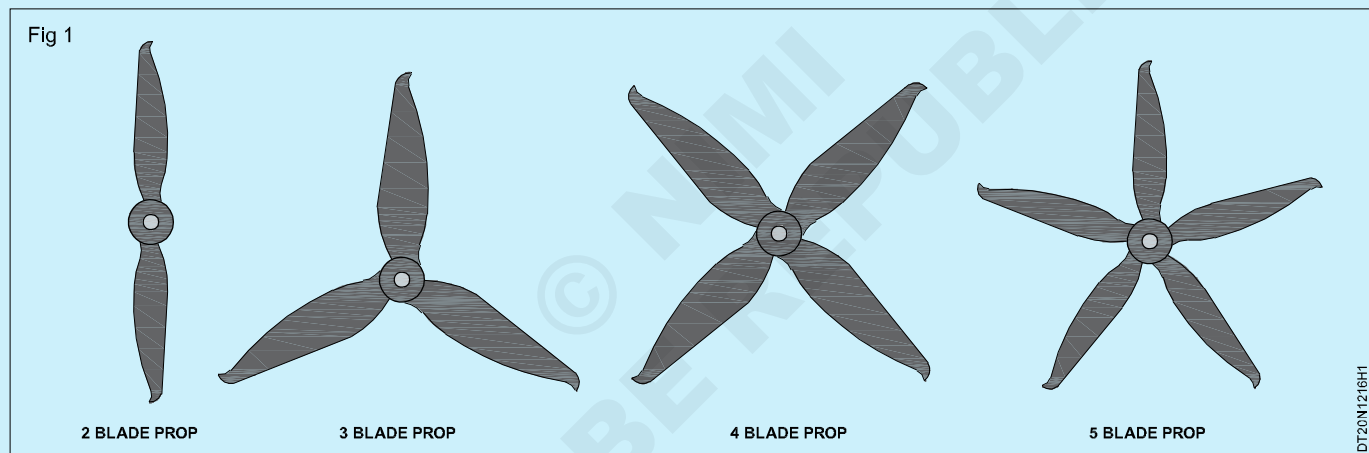

Table 1

S.No	Propeller type	Number of propeller
1		
2		
3		
4		
5		
6		
7		

TASK 2: Design using 3D Printer.

Step 1: Create a Design

Create a propeller design using a 3D design software, like a CAD (computer-aided design) software. (Fig 1)

Step 2: Export the STL File

After created a design, save it in the STL file.

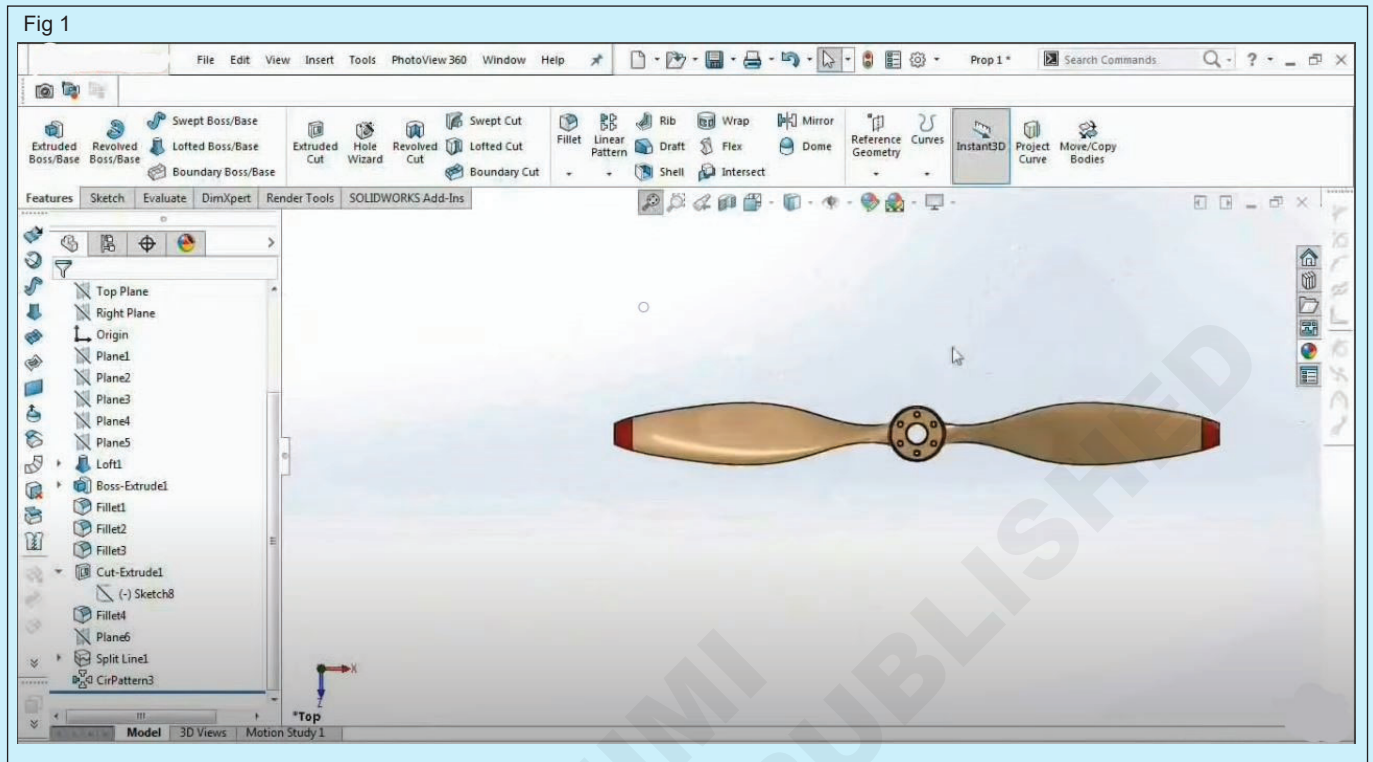

Step 3: Select the Materials

There are many different 3D printing materials (Thermoplastics such as polyester, nylon, polystyrene,

etc.) material available choose one them based on the properties as shown in Table 1.

3D Printing Materials Data				
	Alumide	PA 2200 (Nylon)	UV curable acrylic plastic	ABS
3D printing technology	SLS	SLS	MJM	FDM
accuracy	±0.15mm	±0.15mm	±0.025mm-0.05mm	— ^a
min. wall thickness	0.8mm	0.7mm	0.3mm	— ^a
density	1.36g/cm ³ ^b 0.67g/cm ³ ^c	1.93g/cm ³ ^b 0.45g/cm ³ ^c	1.02g/cm ³	1.05g/cm ³
tensile modulus	3800MPa	1700MPa	1108MPa	1627MPa
tensile strength	48MPa	48MPa	26.2MPa	22MPa
flexural modulus	3600MPa	1500MPa	n/d	1834MPa
flexural strength	72MPa	58MPa	26.6MPa	41MPa
elongation at break	4%	24%	9%	6%
shore D - hardness	76	75	n/d	n/d
thermal properties	172-180°C (melting point) 177°C (heat deflection temp. at 0.45MPa)	172-180°C (melting point)	45°C (heat distortion temp. at 0.45MPa) 80°C (heat softening temp.)	190-240°C (melting point) 90°C (heat deflection temp. at 0.45MPa)
recycling	non recyclable	recyclable	most recyclable	recyclable

Step 4: Enter the Parameters

The next step is then deciding on the different parameters of your object and the printing process. This includes deciding on the size and placement of your print.

Step 5: Create the Gcode

Use the slicing software, like BCN3D Cura. which will convert the information from the STL file into a Gcode(a language that the printer can understand), which is a specific code containing exact instructions for the printer.

Step 6 : Print

The printer will create the object layer by layer.

After printing do some additional post-processing steps like painting, brushing off powder, etc.

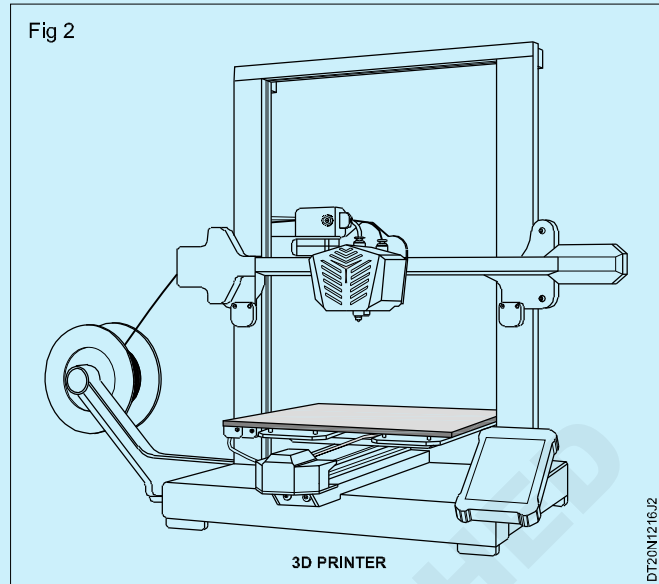

Drone Technician - Identify & Select Different Types of Drones

Design and development of Drone's body component using 3D printer and related software

Objectives: At the end of this exercise you shall be able to

- design of Drone's body component
- development of Drone's body component using 3D printer.

Requirements	
Material	
• 3D printer	- 1 No.
• Laptop	- 1 No.

PROCEDURE

TASK 1: Design and development of Drone's body component

Step 1: Create a Design

Create a drone frame design using a 3D design software, like a CAD (computer-aided design) software.

Step 2: Export the STL File

After created a design, save it in the STL file.

Step 3: Select the Materials

There are many different 3D printing materials (Thermoplastics such as polyester, nylon, polystyrene, etc.) available choose one them based on the properties as shown in Table 1.

Table 1

3D Printing Materials Data				
	Alumide	PA 2200 (Nylon)	UV curable acrylic plastic	ABS
3D printing technology	SLS	SLS	MJM	FDM
accuracy	±0.15mm	±0.15mm	±0.025mm-0.05mm	— ^a
min. wall thickness	0.8mm	0.7mm	0.3mm	— ^a
density	1.36g/cm ^{3b} 0.67g/cm ^{3c}	1.93g/cm ^{3b} 0.45g/cm ^{3c}	1.02g/cm ³	1.05g/cm ³
tensile modulus	3800MPa	1700MPa	1108MPa	1627MPa
tensile strength	48MPa	48MPa	26.2MPa	22MPa
flexural modulus	3600MPa	1500MPa	n/d	1834MPa
flexural strength	72MPa	58MPa	26.6MPa	41MPa
elongation at break	4%	24%	9%	6%
shore D - hardness	76	75	n/d	n/d
thermal properties	172-180°C (melting point) 177°C (heat deflection temp. at 0.45MPa)	172-180°C (melting point)	45°C(heat distortion temp. at 0.45MPa) 80°C (heat softening temp.)	190-240°C (melting point) 90°C (heat deflection temp. at 0.45MPa)
recycling	non recyclable	recyclable	most recyclable	recyclable

Step 4: Enter the Parameters

The next step is then deciding on the different parameters of your object and the printing process. This includes deciding on the size and placement of your print.

Step 5: Create the Gcode

Use the slicing software, like BCN3D Cura. which will convert the information from the STL file into a Gcode(a language that the printer can understand), which is a specific code containing exact instructions for the printer.

Step 6: Print

The printer will create the object layer by layer.

After printing do some additional post-processing steps like painting, brushing off powder, etc.

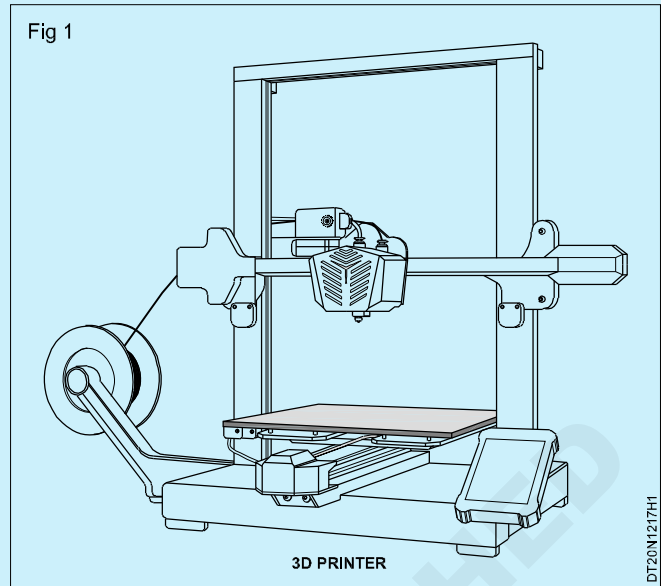

Identify type of motor used in drone

Objective: At the end of this exercise you shall be able to

- identify the different type of motor.

Requirements

Material

- Drone Motor - as per required.

PROCEDURE

Identification of the different type of motor

Instructor may arrange the available different types of motor used in drone in the table or provide the chart showing the motor used in drone. Instructor may also explain the types of motor used in drone and their specification.

- 1 Collect all the type of motor in the workshop
- 2 Identify the motor from the specification given
- 3 Write their names with the help of the chart and note down in Table 1.
- 4 Get it checked by your instructor

Table 1

S.No.	Motor	Specification
1		
2		
3		
4		
5		
6		
7		

Identify & prepare specific flight planning procedures to drone flights

Objective: At the end of this exercise you shall be able to
• **procedures for flight planning.**

PROCEDURE

Planning for Identification and Prapare Specific Flight

- 1 Firstly, Instructor should comply to trainee with the provisions contained in ENR 1.10 of AIP-India. 13.6.11.2
 - 2 Explain the ICAO model flight plan format.
 - 3 Note down UIN of the RPA which is used as aircraft identification for the flight plan.
 - 4 Get the Additional information pertaining to RPA flights may be included under Item 18 of the flight plan. 13.6.11.3
 - 5 Fill the following additional information pertaining to RPA flights should be included in the flight plan:
 - 6 Get the details checked by the instructor
- a Category of RPAS
 - b Type of Operation (VLOS / BVLOS / BRLOS)
 - c Name of Operator and UAOP number
 - d Contact number of Remote Pilot
 - e Purpose of Flight
 - f Payload information
 - g Autonomous Flight Termination / Return Home capability
 - h Geo-fencing capability
 - i Detect and Avoid capability.

Instructor should explain about the ICAO model flight plan format.

Prepare Specific Flight Planning for Specific Drone Flights

© NIMHANS PUBLISHED

NOT TO BE REPRODUCED

Practice drone flying to check to identify faults in drone

Objectives: At the end of this exercise you shall be able to

- identify any defect/faults on the given drone
- record the observed defect/faults on the given drone.

Requirements
<p>Material</p> <ul style="list-style-type: none"> • Drone Motor - 1 No. • Outdoor controlled netted testing facility - as per required.

PROCEDURE

Fault finding on drone

- 1 Take drone to the field and start flying up to some height.
2. Land drone and check the physical defects and problems
- 3 Observe the health function of GPS, FCB, Battery etc
- 4 Note and record your observations in Tables 1.
- 5 Get the work checked by the instructor.

Table 1

Sl.No	Details of fault/defect	Remarks
1		
2		
3		
4		
5		
6		
7		

Fig 1

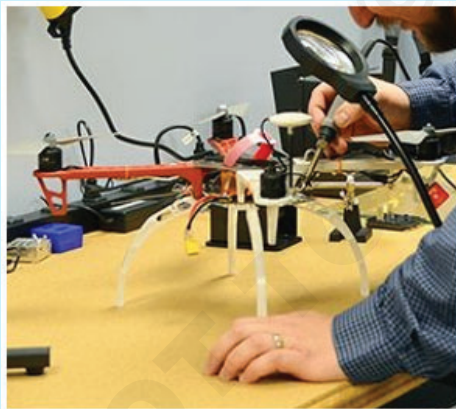

Identify of different types of SMD Components like resistance, capacitance, diode and inductor

Objectives: At the end of this exercise you shall be able to

- identify any defect/faults on the given drone.
- record the observed defect/faults on the given drone.

Requirements	
Material	
<ul style="list-style-type: none"> • Resistors • Capacitors • Inductors 	<ul style="list-style-type: none"> • Diodes • Transistors • IC's packages

PROCEDURE

Identification of SMD Resistors

- 1 Pick one of the SMD resistor and refer to the Fig 1 and Fig 2 identify the coding marked on the component.

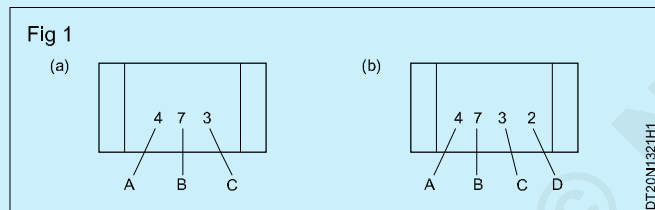

- 2 Decode the value referring to the Chart 1 & Chart 2
- 3 Record the observations in Table 1

Resistors are frequently marked with a threedigit number and some typical values are shown in chart 4. The first two numbers are the significant digits of the value, and the last digit is the multiplier (the number of zeros to add to the first two digits). For example, a chip resistor labeled 102 has a value of 1000 Ohms, or 1k Ohms.

Marking on the SMD resistors

- A = 1st digit of the resistors value
- B = 2nd digit of the resistors value
- C = number of zeros

Chart 1

Code letters printed	Resistance value
101	100 Ω
471	470
102	1k
122	1.2k
103	10k
123	12k
104	100k
124	120k
474	470k

Typical resistor markings and corresponding values

- A = 1st digit of the resistor value
- B = 2nd digit of the resistor value
- C = 3rd digit of the resistor value
- D = number of zeros

- 4 By using the above technique, find values of resistors for those components whose values are printed as below and record in Table 1.

Chart 2

Printed Code letters	Resistance value
100R	100
634R	634
909R	909
4701	1k
1002	4.7k
1502	10k
1502	15k
5493	549k
1004	1M

Table 2

Printed Code letters	Resistance value
102	---Ω
470	---Ω
103	---Ω
222	---Ω
101	---Ω
232	---Ω
333	---Ω
1243	---Ω
4743	---Ω

© NIMI
NOT TO BE REPUBLISHED

Measure different components values using SMD Technology Kit, Tweezers and DMM

Objectives: At the end of this exercise you shall be able to

- **measure values of SMD**
- **uses of DMM.**

Requirements
<p>Tools</p> <ul style="list-style-type: none"> • Smart SMD tweezer Handheld - 1 No. • Handheld 3 3/4 Digit Multimeter - 1 No.

PROCEDURE

TASK 1: Measure resistance value

- 1 Take the resistor and hold with tweezers.
Turn digital multimeter dial to resistance, or ohms

Display should show OLΩ

- 2 Connect the black test lead into the COM jack and the red lead into the VΩ jack.
- 3 Connect test leads across the component being tested.
- 4 Read the measurement on the display.
- 5 When finished, turn the multimeter OFF to prevent battery drain.

Make sure that contact between the test leads and circuit is good.

Measure the resistance of each resistor and complete the below table

TASK 2: Measure Capacitance value

- 1 Take the capacitance and hold with tweezers
- 2 Take digital multimeter (DMM).

Consult your multimeter’s user manual for instructions.

Set the multimeter to measure ac or dc voltage as

- 3 Turn the dial to the Capacitance Measurement mode.
- 4 For a correct measurement, the capacitor will need to be removed from the circuit.

Table 1

S.NO	Measured Value (using DMM)
1	
2	
3	
4	
5	
6	

Note: Do not touch both resistor leads while making the measurement, if you do so, DMM will measure your body resistance as well as the resistor.

Discharge the capacitor before measurement

- 5 Connect the test leads to the capacitor terminals. Keep test leads connected for a few seconds to allow the multimeter to automatically select the proper range.
- 6 Read the measurement displayed.
- 7 It will display OL if a) the capacitance value is higher than the measurement range or b) the capacitor is faulty.

Measure the value of capacitance using DMM and complete the below table

Table 2

S.NO	Measured Value (using DMM)
1	
2	
3	
4	
5	
6	

TASK 3: Measure Diodes value

- 1 Before measurement make sure a) all power to the circuit is OFF and b) no voltage exists at the diode. Voltage may be present in the circuit due to charged capacitors. If so, the capacitors need to be discharged.
- 2 Turn the dial to Resistance mode (Ω). It may share a space on the dial with another function.
- 3 Connect the test leads to the diode after it has been removed from the circuit. Record the measurement displayed.
- 4 Reverse the test leads. Record the measurement displayed.
- 5 For best results when using the Resistance mode to test diodes, compare the readings taken with a known good diode.

Set the multimeter to measure ac or dc voltage as
--

Table 3

S.NO	Measured Value (using DMM)
1	
2	
3	
4	
5	
6	

Identify of different types of SMD IC packages

Objectives: At the end of this exercise you shall be able to

- identify of different types of SMD IC packages.

Requirements

Material

- SMD Technology Kit with wall chart - 1 No.

PROCEDURE

Identify of different types of SMD IC packages

- 1 Pick one of the SMD IC package from the Workbench.
- 2 Identify and record the name of the IC package in Table – 1
- 3 List the use/application in Column-3 of the table.
- 4 Repeat above step for the remaining IC package.
- 5 Get the work checked by the instructor.

Table 1

S.NO	Name of the IC package	Use/application
1		
2		
3		
4		
5		
6		

The instructor has to arrange the SMD IC package.

Explore and configure SMD soldering and de-soldering rework station

Objectives: At the end of this exercise you shall be able to

- identify of different types of SMD IC packages.

Requirements	
<p>Tools/Equipments/Instruments</p> <ul style="list-style-type: none"> • Trainees tool kit - 1 Set • Digital multimeter with probes - 1 No • SMD soldering workstation with all accessories and operating manual - 1 Set <p>Aids : Charts showing panel controls of soldering workstation - 1 No</p>	<p>Material/Components</p> <ul style="list-style-type: none"> • Solder wire 60/40 rosin core - as reqd. • Solder flux pen/liquid flux - as reqd. • Clearing brush - 1 No.

PROCEDURE

TASK 1: Explore rework station

- 1 Refer to the operating manual Fig 1 and Fig 2 Identify the front panel controls/switches on the soldering workstation, with reference to the operating manual.

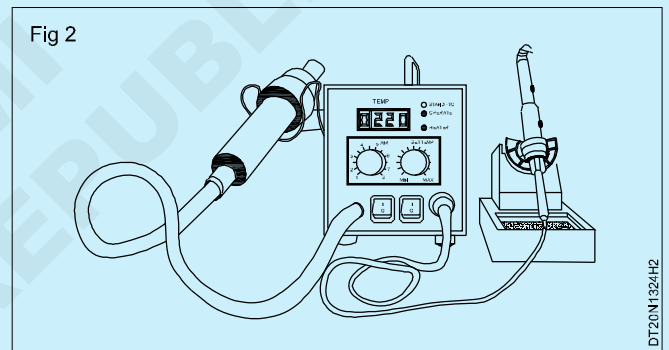
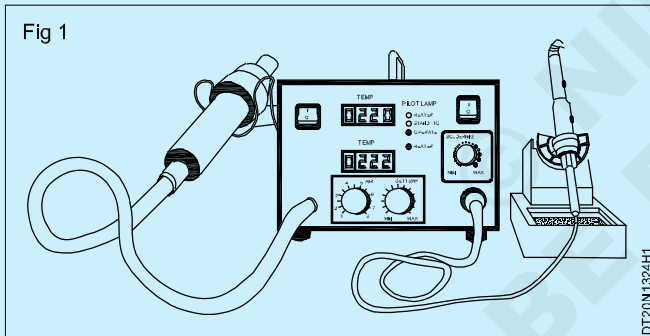

- 2 Record the name of the control/switch and its function on the Table -1.
- 3 Identify the accessories used with the soldering workstation and record them in Table - 1.
- 4 Get the work checked by the instructor.

Table 1

Sl. No.	Name of the control/Switch/ accessory	Functions/Uses Specifications	Remarks
1			
2			
3			
4			
5			
6			
7			

TASK 2: Setting the soldering station for SMD Component Soldering work

- 1 Select and fix the suitable bit/ tip onto the soldering iron for the SMD Component soldering work.
- 2 Select and fix appropriate size of hot air nozzle suitable for the soldering work.
- 3 Switch ON the soldering work station and set the temperature at 275°C.
- 4 Adjust the hot air pressure control knob to the mid position.
- 5 Test the soldering iron heat by keeping the solder wire on the tip for melting.
- 6 Record the settings control position, temperature observations on the Table 2.
- 7 Get the work checked by the instructor and switch OFF the soldering workstation.
- 4 Refer to adjust controls on the trent the operating manual panel of the soldering workstation for 275° c temperature and record it in the Table-2 turn on soldering station
- 6 Set proper tip temperature
- 7 Now adjust the soldering workstation is ready to work for soldering / desoldering
- 8 Get the worm checked by the instructor Table 2.

Note: The Instructor has to ensure that all the controls/switches on the panel are kept in zero position before given to trainees.

Note : At the time of soldering SMD components, the controls may be re-adjusted for required temperature/air pressure actually needed for the soldering work.

Table 2

Sl. No.	Name of the control/Switch/ accessory	Setting/Position	Temperature/Air pressure	Remarks
1				
2				
3				
4				
5				
6				
7				

Practice soldering and de-soldering the SMD components on the PCB

Objectives: At the end of this exercise you shall be able to

- solder the SMD Components on the PCB
- desolder the SMD Components from the PCB.

Requirements			
Tools/Equipments/Instruments		Material/Components	
• Trainees tool kit	- 1 Set	• Desoldering wick	- as reqd.
• Magnifier with lamp	- 1 No.	• Solder flux pen/liquid flux	- as reqd.
• SMD rework station with hot air nozzles/temperature/floor controller with instruction manual	- 1 Set	• IPA Cleaning solution	- 1 No.
• DMM with probes	- 1 No.	• Piece of medium density fiber board (MDF)	- 1 No.

PROCEDURE

TASK 1: Solder the SMD component from the PCB

- 1 Choose and fit the appropriate tip for the soldering iron suitable to the SMD component onto the PCB.
- 2 Use crocodile clips to hold the PCB firmly on the workbench.
- 3 Select the SMD components and note down the location/ direction on the PCB to be soldered.
- 4 Switch ON the soldering workstation and adjust the temperature setting knob around 275°C.
- 5 Keep the SMD component over the pads on the printed circuit at its position correctly.
- 6 Use flux pen and apply a little quantity on the places where soldering has to be done.
- 7 Cut the solder wire into small pieces and place them on SMD component leads.
- 8 Hold the component using tweezers and apply the hot soldering iron tip over the solder pieces to melt.
- 9 Remove the soldering iron tip and allow the molten solder to set on the pin.
- 10 Repeat steps to solder the other end of the SMD component.
- 11 Use magnifier and inspect the soldered joints are free from any solder bridges
- 12 Clean the board using IPA solution with brush
- 13 Get the work checked by the instructor.

Caution: To avoid thermal buildup, solder the terminals alternately with little time interval between pins.

TASK 2: Solder the SMD component from the PCB.

- 1 Collect the defective SMD-PCB from the Instructor and identify the components to be removed.
- 2 Use magnifying glass and inspect the size of solder joints on the components to be removed as shown in the Fig 1
- 3 Apply a small quantity of flux and solder to the joints of the surface mount components to be removed.
- 4 Place one end of solder wicking braid on the component lead side and the tip of the soldering iron over it as shown in Fig 2

Fig 1

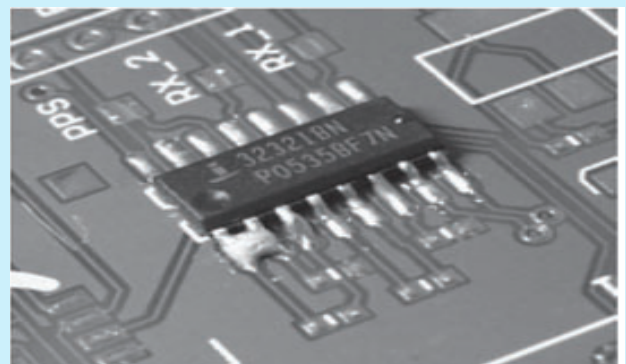

Fig 2



- 5 Allow time for the solder to melt and the solder wick to draw the molten solder into the braid by capillary action.
- 6 After the molten solder has been extracted from the joint, remove the wick and the soldering iron tip from the component lead.
- 7 Use the unused portion of the wick for removing excess solder.
- 8 Repeat the steps 3 to 7 for removing other terminals of the surface mount components.
- 9 Remove the components from the PCB and clean the surface, using IPA solution.
- 10 Get the work checked by the instructor.

© NIMI
NOT TO BE REPUBLISHED

Practice soldering and de-solder various IC's of different packages

Objectives: At the end of this exercise you shall be able to

- practice soldering various IC's of different packages
- practice de-solder various IC's of different packages.

Requirements	
<p>Tools/Equipments/Instruments</p> <ul style="list-style-type: none"> • SMD soldering workstation - 1 Set • Magnifier with lamp - 1 No • Tweezers - 1 Set 	<p>Material/Components</p> <ul style="list-style-type: none"> • Solder flux pen/liquid flux solder wick, IPA solutions cleaning cotton bud - as reqd. • Solder paste - as reqd. • SMD IC - as reqd. • Flexible PCB tape - as reqd.

PROCEDURE

Soldering of IC using soldering workstation/hot air

- 1 Pick the SMD IC and the PCB-2; Identify the pin-1 mark on the land pattern of the PCB as shown in Fig 1

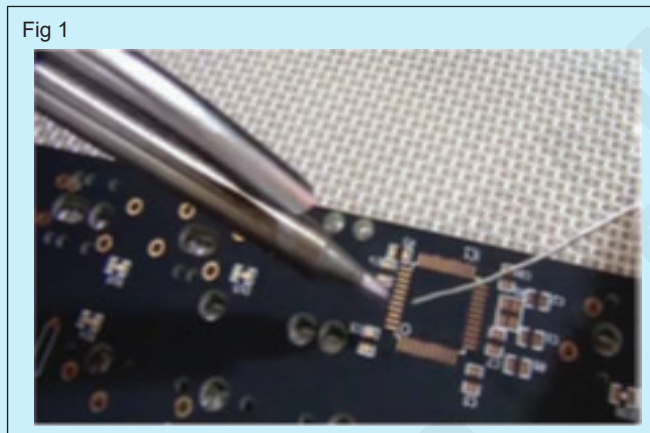

- 2 Clean the solder pad with IPA solution and tin the 1st pin, diagonally opposite pin pads.
- 3 Use holding device with crocodile clips to fix the PCB firmly on the work bench.
- 4 Switch ON the soldering workstation, adjust the temperature setting knob to 275°C.
- 5 Use the ESD safe tweezers and place the SMD IC on the pads of the PCB at its position correctly as shown in Fig 2.

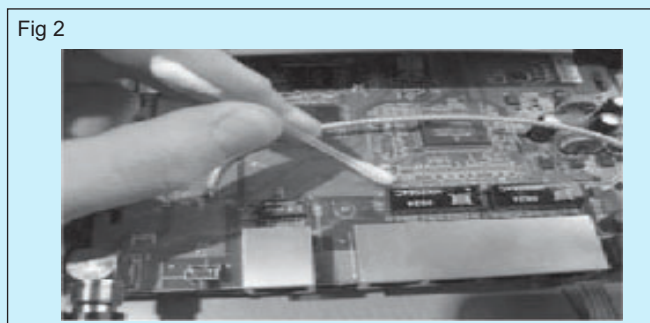

Hold the IC firmly and solder the pin-1 using pencil tip soldering iron and solder the diagonally opposite pin; switch OFF power.

- 7 Check the alignment using magnifier and confirm the SMD ICs correct position on the PCB as shown in Fig 3

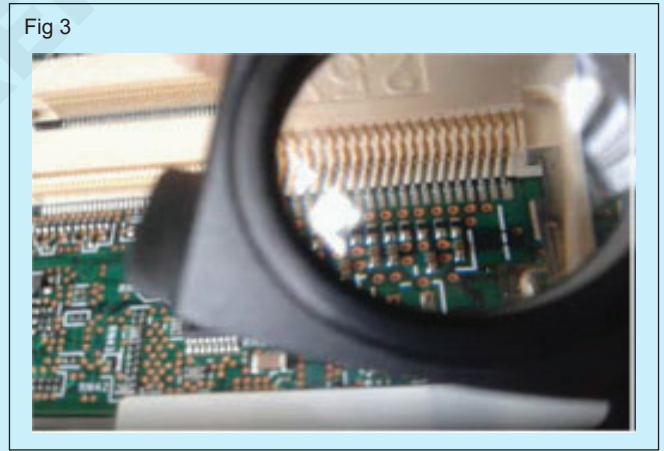

Caution: To avoid damage do not keep the hot air nozzle over the device and adjacent components for a longer period of time and burning of the PCB. Don't blow air by mouth; it may cause dry solder.

Apply the solder paste over the pins on all the four sides of the SMD IC.

- 9 Power ON the soldering workstation and adjust the air and temperature knobs to 280°C.
- 10 Apply the hot air nozzle over the SMD IC leads on all the four sides.
- 11 Keep the hot air nozzle moved around till the solder paste slowly melts and the solder joints formed on the pads of PCB.

12 Use magnifier and check all the pins of the SMD IC are correctly soldered to the pads on the PCB.

Note: Solder the pins using soldering iron with pencil tip if needed

13 Clean the soldered PCB using IPA solution with brush.

14 Get the work checked by the instructor

Repeat the above steps for various SMD IC packages like SOP, SSOP, TSOP, TSSOP, SOIC, SOT packages

TASK 2 : Desoldering of IC using soldering workstation/hot air

- 1 Select the blower tip of the Soldering workstation suitable to the IC to be removed.
- 2 Apply solder flux over the IC or chip using the 5ml syringe as shown in Fig 4

Fig 4

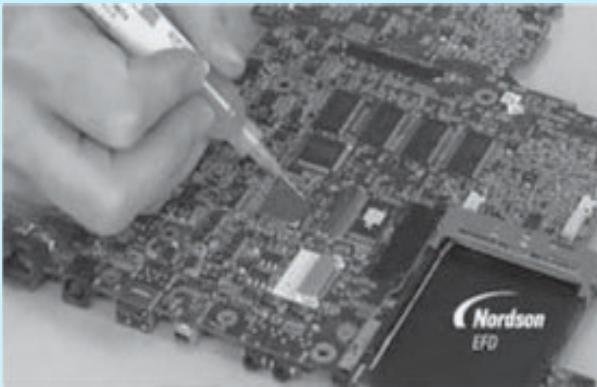

- 3 Adjust and set the temperature and apply the hot air over the IC to be removed as shown in Fig 5

Fig 5

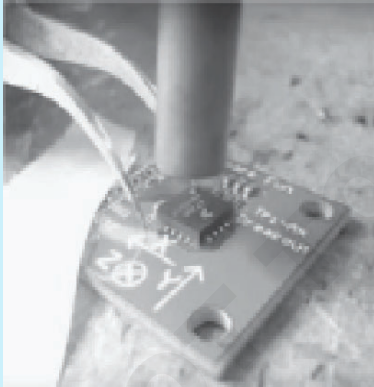

Note: The Instructor has to ensure that the masking of the other components using Kapton tape is done before starting the desoldering of IC.

- 4 Slowly try to insert the tweezers to lift from one side and remove the IC from the PCB as shown in Fig 6
- 5 Take away the IC using tweezers as shown in Fig 7
- 6 Remove any excess solder over the pads using solder wick as shown in Fig 8
- 7 Clean the solder pads using IPA solution with cotton buds/brush as shown in Fig 9

Fig 6

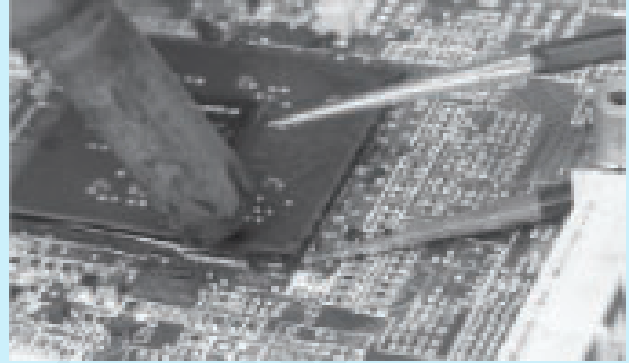

Fig 7

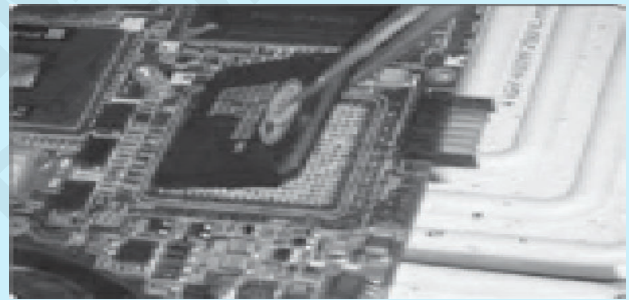
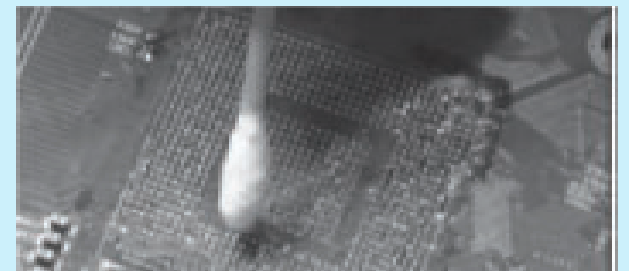

Fig 8



Fig 9



- 8 Check the pad of the IC using magnifier lens is cleaned.
- 9 Verify no pad is damaged as shown in Fig 10
- 10 Get the work checked by the Instructor.

Fig 10



© NIMI
NOT TO BE REPUBLISHED

Drone Technician - Measure Different Type Electrical Parameters and Record The Data Related with Drone Hardware

Identify the type of electronic instruments

Objectives: At the end of this exercise you shall be able to

- identification the type of electronic instruments.

Requirements	
Tools/Equipments/Instruments	
<ul style="list-style-type: none"> • Different types of electronic • Electrical cables 	<ul style="list-style-type: none"> • Connectors, sockets, terminations, Different types of Analog electronic components, digital ICs.

PROCEDURE

Identification of different types of electronic instruments

- 1 Pick anyone instrument
- 2 Check the function of instrument.
- 3 Record the instrument type in Table 1.
- 4 Repeat the above steps for other electronic instrument.
- 5 Get the Table 1 checked by instructor.

Table 1

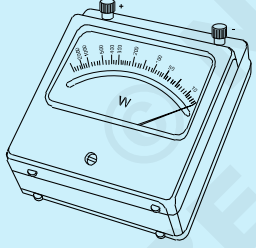
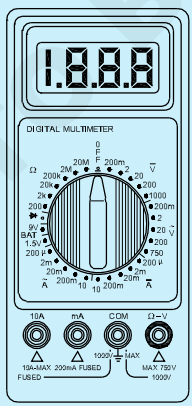
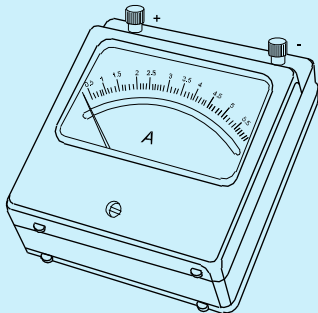
S.No.	Electronic Instruments	Type
1		
2		
3		

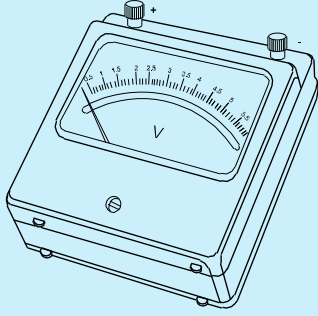
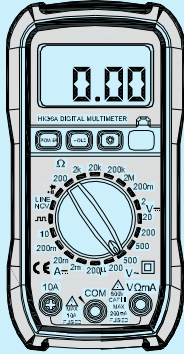
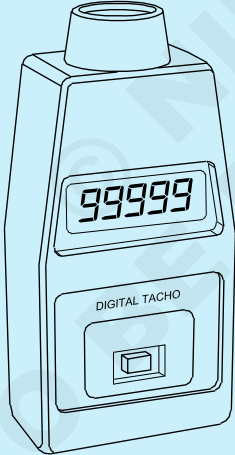
4		
5		
6		

NOT TO BE PUBLISHED

Drone Technician - Measure Different Type Electrical Parameters and Record The Data Related with Drone Hardware

Measure the resistance, Voltage, Current through series and parallel connected networks using multi meter

Objectives: At the end of this exercise you shall be able to

- connect the circuit elements in series and test
- measure and verify Voltage, Current, Resistance in series circuit
- connect the circuit elements in parallel and test
- measure and verify voltage, Current, Resistance in parallel circuit.

Requirements

Tools/Equipments/Instruments

• Trainees Tool Kit	- 1 Set
• Soldering iron, 230V/25 watts	- 1 No.
• Ammeter, 0-25mA, DC	- 1 No.
• Ammeter, 0-100mA, DC	- 1 No.
• Ammeter, 0-200mA, DC	- 1 No.
• Ammeter, 0-500mA, DC	- 1 No.
• Voltmeter, 0-15 V DC	- 1 No.
• Multimeter with probes	- 1 No.
• DC Regulated power supply, 0-30V/2A	- 1 No.

Material/Components

• SPST Toggle Switch/1A	- 1No.
• Resistor 100 Ω $\frac{1}{2}$ watts	- 1No.
• Resistor 150 Ω $\frac{1}{2}$ watts	- 1No.
• Resistor 220 Ω $\frac{1}{2}$ watts	- 1No.
• Hook-up wires	- 1No.
• Patch Cords	- 1No.
• Lug Board	- 1No.
• Rosin cored solder	- 1No.
• Soldering flux	- 1No.

PROCEDURE

Measurements on Series Circuit

- 1 Connect the resistors in series and also wire up the voltmeters and ammeters as shown in Fig 1.

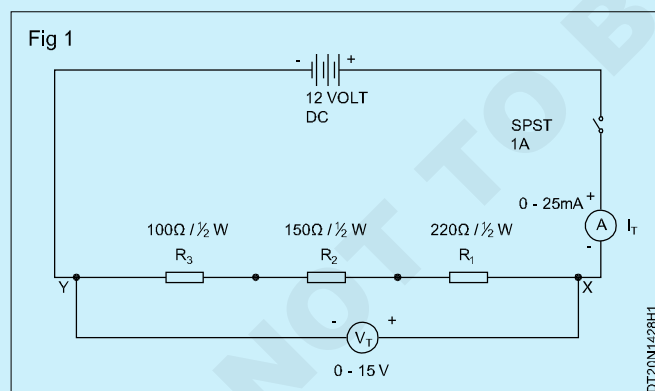

- 2 Measure resistance across each resistor using multi-meter and record in Table-1.
- 3 Measure the total resistance using multi-meter between the terminals X & Y.
- 4 Switch ON the RPSU and set the output voltage to 12 volts.
- 5 Close the switch and measure the current (I_T) and voltage (V_T).
- 6 Enter the measured value in table-1.

- 7 Switch OFF the supply. Reconnect the ammeter and voltmeter as shown in Fig 2.

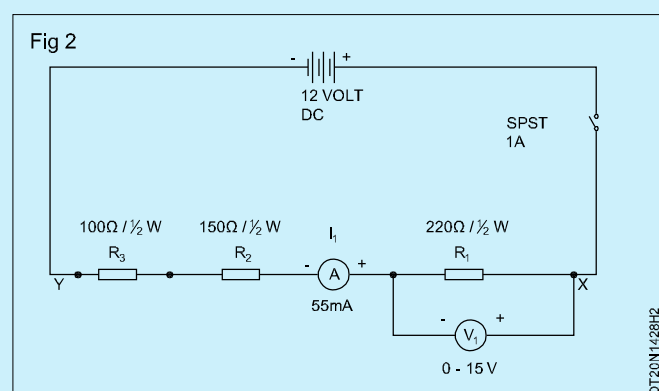

- 8 Measure and record the voltage (V_1) and current (I_1) through resistor R_1 .
- 9 Switch OFF the supply. Reconnect the ammeter and voltmeter as shown in Fig 3.
- 10 Measure and record the Voltage (V_2) and Current (I_2) through Resistor R_2 .
- 11 Switch OFF the supply. Reconnect the ammeter and voltmeter as shown in Fig 4.

- 12 Measure and record the Voltage (V_3) and Current (I_3) through Resistor R_3 .
- 13 Calculate total resistance, total current, total voltage using measured values.
- 14 Verify the laws of series circuit and compare the values with the calculated values.
- 15 Get the work checked by the Instructor.

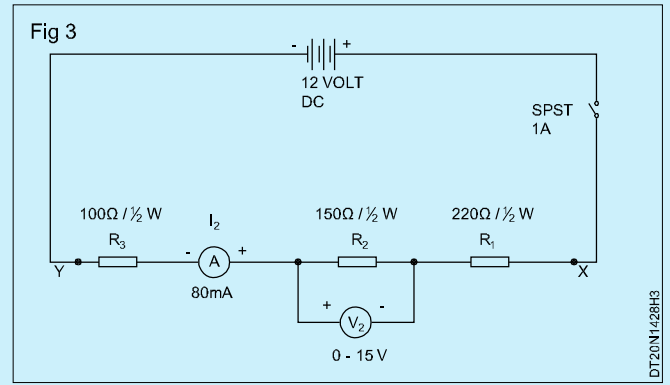

Table 1

R_1	R_2	R_3	R_T	V_T	I_T	V_1	I_1	V_2	I_2	V_3	I_3

Drone Technician - Measure Different Type Electrical Parameters and Record The Data Related with Drone Hardware

Measure AC and DC voltage using Digital Multi-meter

Objectives: At the end of this exercise you shall be able to

- measure the AC voltage using multimeter
- measure the DC voltage using multimeter.

Requirements	
Tools/Equipments/Instruments <ul style="list-style-type: none"> • Digital multimeter with probes - 1 No. • Analog multimeter with probes - 1 No. 	Material/Components <ul style="list-style-type: none"> • Lead acid battery 6V/12V any AH rating - 1 No. • 1.5V/3V/9V battery - 1 No. each

Note: The instructor has to label the cells and batteries used for this exercise/Task

PROCEDURE

TASK 1: Measurement of cell/battery voltage using analog multimeter

- 1 Observe the front panel and insert the black colour probe “COM” socket of analog multimeter and insert the red colour probe into the V mA Ω socket as shown in Fig 1.

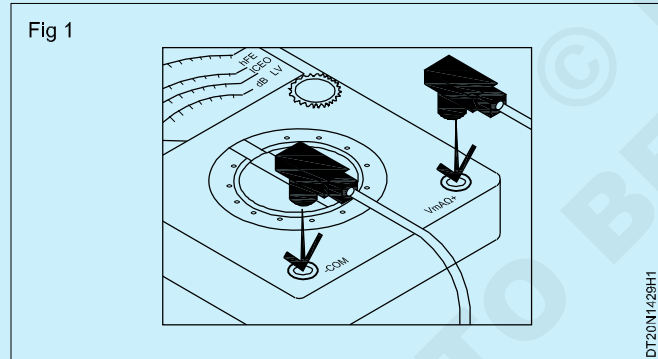

- 2 Set the range selector knob of multimeter to DCV, as shown in Fig 2.
- 3 Set the voltage range nearest to the cell/battery voltage as shown in Fig 3.
- 4 Pick the 9V battery, place the black probs on the negative (-) terminal and red probe on the positive (+) terminal of the battery as shown in Fig 4.
- 5 Check the analog voltmeter reading as shown in Fig 5 and record the reading in table 1.
- 6 Repeat step 4 and 5 for the remaining labelled cells/ battery.
- 7 Get the work checked by the instructor.

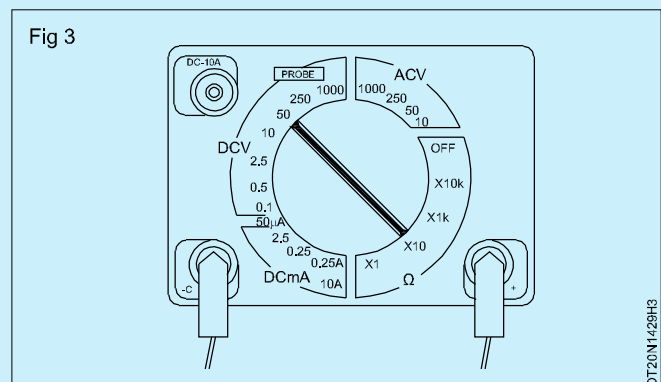
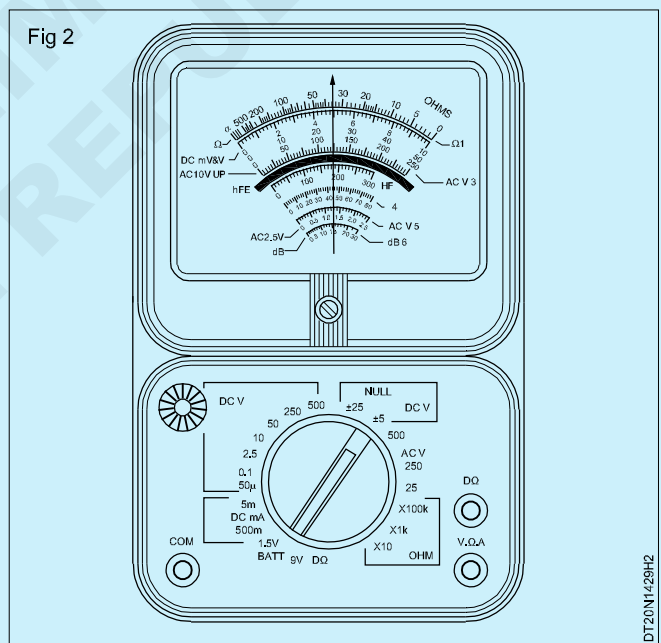

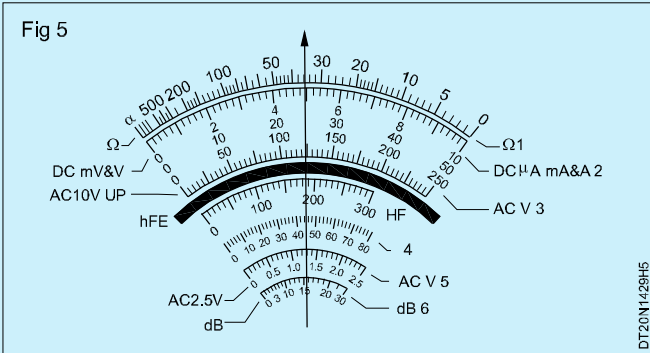
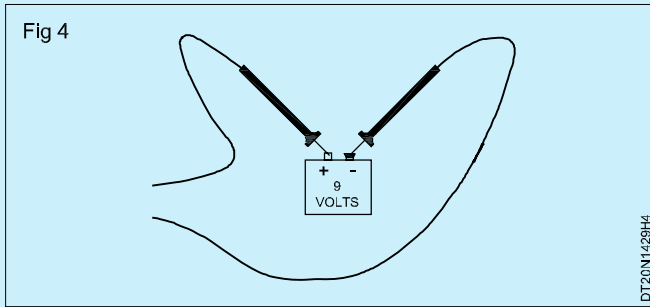

Table 1

Label No	Voltage marked on the cell/ battery	Meter range selected	Measured reading

Note: Read just the voltage selector knob of the analog meter suitably measure the cell/ battery voltage with accuracy of deflection of the pointer on the calibrated scale.

TASK 2: Measurement of cell/battery voltage using Digital Multimeter

- 1 Plug the black colour probe into the COM socket on the digital multimeter and red colour probe into the V Ω mA socket.
- 2 Turn the multi meter knob to the DC Voltage selection as shown in Fig 1.

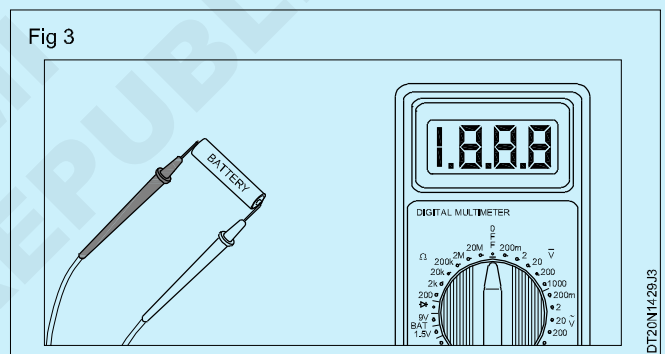
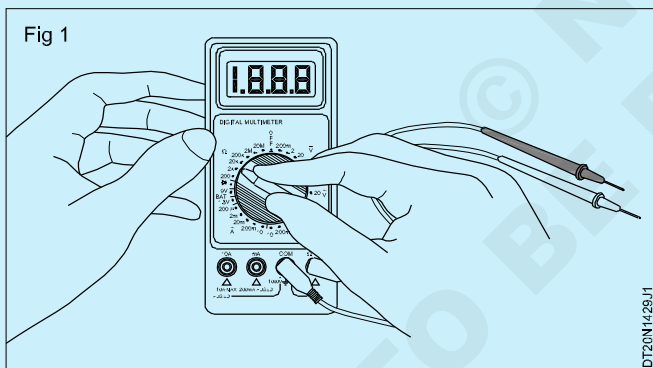

- 3 Pick one of the labelled battery and measure the terminal voltage as shown in Fig 2.
- 4 Observe the reading displayed on the digital meter and record it in Table 2.

Table 2

Label No	Voltage marked on the cell/ battery	Meter range selected	Measured reading

- 5 Repeat step 3 and 4 for other labelled batteries also.

Note: For accurate measurement, the voltage range selector of digital meter may be readjusted suitably.

- 6 Get the work checked by the instructor.

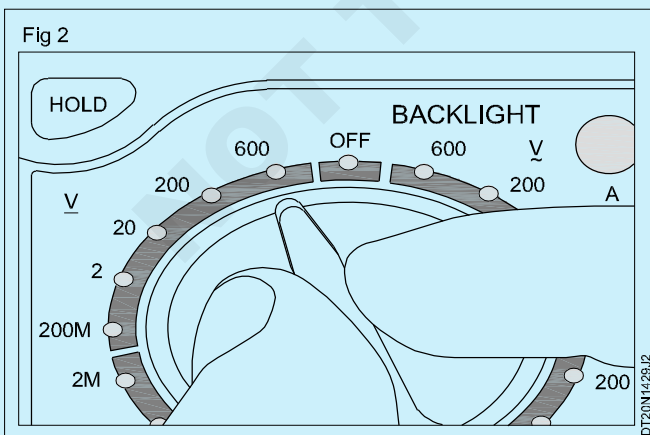

Note: Most digital multimeter power up in Auto range mode. This automatically selects a measurement range based on voltage present

Drone Technician - Measure Different Type Electrical Parameters and Record The Data Related with Drone Hardware

Measure AC and DC current using Digital Multi-meter

Objective: At the end of this exercise you shall be able to
 • measure AC and DC current using Digital Multi-meter.

Requirements	
Tools/Equipments/Instruments	Material/Components
<ul style="list-style-type: none"> Digital Multimeter with probes - 1 Set Auto transformer (VARIAC) single phase having input 0-220V AC output 0-270VAC/15A - 1 No. 	<ul style="list-style-type: none"> Dry cell 1.5 V / AA size - as reqd. 3V CR 2032 Lithium - as reqd. 9V battery (Alkaline type) - as reqd. 12 V battery (SMF type) AH rating available in the section - as reqd.

Note:
 1 The instructor has to explain the differences between the analog multimeter and DMM.
 2 Provide an analog multimeter to trainees and instruct them to study the panel/ranges/scales/selector switch/socket etc., in it.

PROCEDURE

TASK 1: Measurement of AC Current using multimeter.

- 1 Observe and check the number of available ranges in the given multimeter.
- 2 Plug the black colour probe into the COM socket and plug the red colour probe into the socket of multimeter as shown in Fig 1.

Safety precaution:
Note: Before power ON auto transformer keep the voltage selector knob in 0V, position.

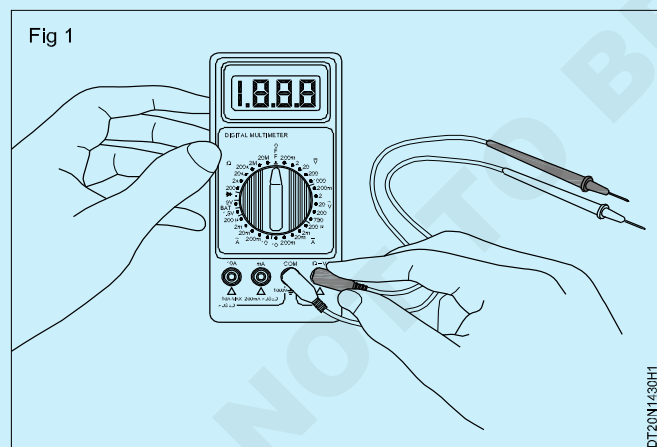

- 3 Select the multimeter knob (switch) to the AC Current range.

Note : Most multimeters power up in Auto range mode. This automatically selects a measurement range based on Current present.

- 5 Power ON the Auto Transformer observing the multimeter increase the Current to 10 volt.
- 6 Record the observation in Table 1.
- 7 Repeat the above step in steps of 10V up to 50V notedown the corresponding readings in Table 1.
- 8 Get the work checked by the instructor
- 9 Bring down the Current selector to 0V position and switch OFF the variac.

Table 1

S.No	Variac dial position	Meter reading	Remarks
1			
2			
3			
4			
5			
6			

Connect the meter across the autotransformer output socket.

TASK 2: Measurement of DC Current using multimeter.

- 1 Select the multimeter knob (switch) to the DCV or V Current section as shown in Fig 2.

Take the 9V battery identify supply terminals place the red probe on the positive terminal, and the black probe on the negative terminal.

Note: If the range was set too high, may not get a very accurate reading. Turn the dial to a lower range to get a better reading.

- 3 With the range set correctly, as shown in Fig 3, measure the Current of the battery and record the readings in Table 2.

- 4 Repeat the above steps for other battery and record the reading in Table 2.

Table 2

S.No	Battery type	Mark readings	Remarks
1	1.5 V		
2	2.3 V		
3	3.9 V		
4	4.12 V		

- 5 Get the work checked by the instructor.

© NIMI
NOT TO BE REPUBLISHED

Drone Technician - Measure Different Type Electrical Parameters and Record The Data Related with Drone Hardware

Measure frequency using Digital Multi-meter

Objectives: At the end of this exercise you shall be able to
 • **measure the frequency using Digital Multi-meter.**

Requirements			
Tools/Equipments/Instruments		Material/Components	
• Digital Multimeter with probes	- 1 Set	• Dry cell 1.5 V / AA size	- as reqd.
• Auto transformer (VARIAC) single phase having in put 0-220V AC output 0-270VAC/15A	- 1 No	• 3V CR 2032 Lithium	- as reqd.
		• 9V battery (Alkaline type)	- as reqd.
		• 12 V battery (SMF type) AH rating available in the section)	- as reqd.

PROCEDURE

TASK 1: Digital multimeters with a frequency symbol on the dial.

- 1 Turn the dial to Hz.
- 2 First insert the black test lead into the COM jack.
- 3 Then insert the red lead into the V Ω jack.
- 4 Connect the black test lead first, the red test lead second.
- 5 Read the measurement in the display record the readings in Table - 1.
- 6 Get the work checked by the instructor.

Table 1

S No	Mark Readings	Remarks
1		
2		
3		
4		
5		
6		

Fig 1



TASK 2: Digital multimeters with a frequency button.

- 1 Turn the dial to ac voltage (AC Voltage indicator). If voltage in the circuit is unknown, set the range to highest voltage setting.
- 2 First insert the black test lead into the COM jack.
- 3 Then insert the red lead into the V Ω jack.
- 4 Connect the test leads to the circuit.
- 5 Read the voltage measurement in the display.
- 6 With the multimeter still connected to the circuit, press the Hz button.
- 7 Read the frequency measurement in the display.

Table 2

S No	Mark Readings	Remarks
1		
2		
3		
4		
5		
6		

Drone Technician - Measure Different Type Electrical Parameters and Record The Data Related with Drone Hardware

Measure the analog signals like of peak-to-peak voltage, frequency, time period, and duty cycle using of DSO

Objectives: At the end of this exercise you shall be able to

- measure the time, frequency and amplitude of a square/ rectangular waveform
- measure the time, frequency and amplitude of a sine waveform
- measure the time, frequency and amplitude of two signals to compare the phase shift.

Requirements			
Tools/Equipments/Instruments			
• Digital Multimeter with probes	- 1 Set	• Signal generator with manual	- 1 No
• Analog trainer kit with manual	- 1 No		

PROCEDURE

TASK 1: Taking Automatic Measurements of square wave forms

The oscilloscope can take automatic measurements of most displayed signals, to measure signal frequency, period, and peak-to-peak amplitude. The following steps may be followed.

- 1 Connect a signal generator to a DSO and switch on the DSO and signal generator. Set signal generator frequency at 1kHz and amplitude at 5V as in Fig 1.
- 2 Push the **MEASURE** button to see the Measure Menu.
- 3 Push the top option button; the **Measure 1** Menu appears. Push the Type option button and select Freq. The Value readout displays the measurement and updates.

NOTE: If a question mark (?) displays in the Value readout, turn the VOLTS/DIV knob for the appropriate channel to increase the sensitivity or change the SEC/DIV setting.

- 4 Push the **Back** option button.
- 5 Push the second option button from the top; the **Measure 2** Menu appears.
- 6 Push the Type option button and select Period. The Value readout displays the measurement and updates.
- 7 Push the **Back** option button.
- 8 Push the middle option button; the Measure 3 Menu appears.
- 9 Push the Type option button and select Pk-Pk. The Value readout displays the measurement and updates. (*Pk-Pk= Peak - Peak)

- 10 Push the **Back** option button.
- 11 Push the second option button from the bottom; the Measure 4 Menu appears.
- 12 Push the Type option button and select Rise Time. The Value readout displays the measurement and updates.
- 13 Push the **Back** option button.
- 14 Push the bottom option button; the Measure 5 Menu appears.
- 15 Push the Type option button and select PosWidth. The Value readout displays the measurement and updates.
- 16 Push the **Back** option button.
- 17 Repeat steps 2 to 15 by varying amplitude and frequency.
- 18 The steps 2 to 11 may be followed by connecting other type of waveforms (sine wave and triangular wave).

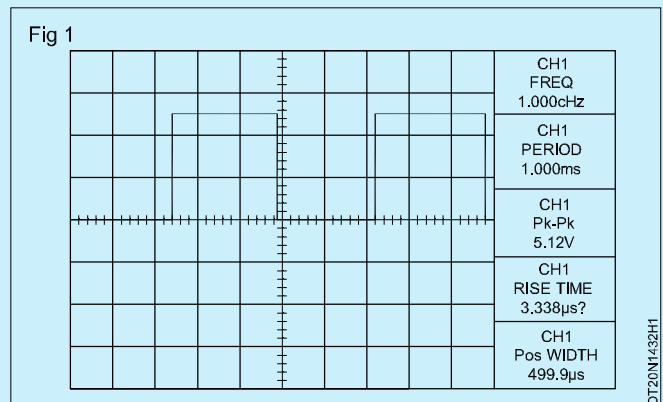

TASK 2: Measure the time, frequency and amplitude of a two signals to compare the phase shift

To activate and display the signals connected to channel 1 and to channel 2,

- 1 Construct the amplifier as shown in Fig 2 using the trainer kit. If trainer kit is not available in the lab, construct the circuit using discrete components on breadboard/PCB.
- 2 Connect two oscilloscope channels to the amplifier input and output as shown.
- 3 If the channels are not displayed, push the CH 1 MENU and CH 2 MENU buttons.
- 4 Push the AUTOSSET button.
- 5 Push the Measure button to see the Measure Menu

Note: Any amplifier circuit may be used to perform this experiment.

- 6 Push the top option button; the Measure 1 Menu appears.
- 7 Push the Source option button and select CH1.
- 8 Push the Type option button and select Pk-Pk.
- 9 Push the Back option button.

10 Push the second option button from the top; the Measure 2 Menu appears

11 Push the Source option button and select CH2.

12 Push the Type option button and select Pk-Pk.

13 Push the Back option button

14 Read the displayed peak-to-peak amplitudes for both channels and observe the phase differences between the wave forms. It may appear as shown in Fig 2.

15 Vary the frequency and amplitude one by one and repeat the step 14 record your reading in the table 1.

16 Performs step 15 till you can read the values thoroughly.

17 Get the work checked by the instructor.

Sl No	Frequency	V _{in}	V _{out}	Gain=V _{out} /V _{in}

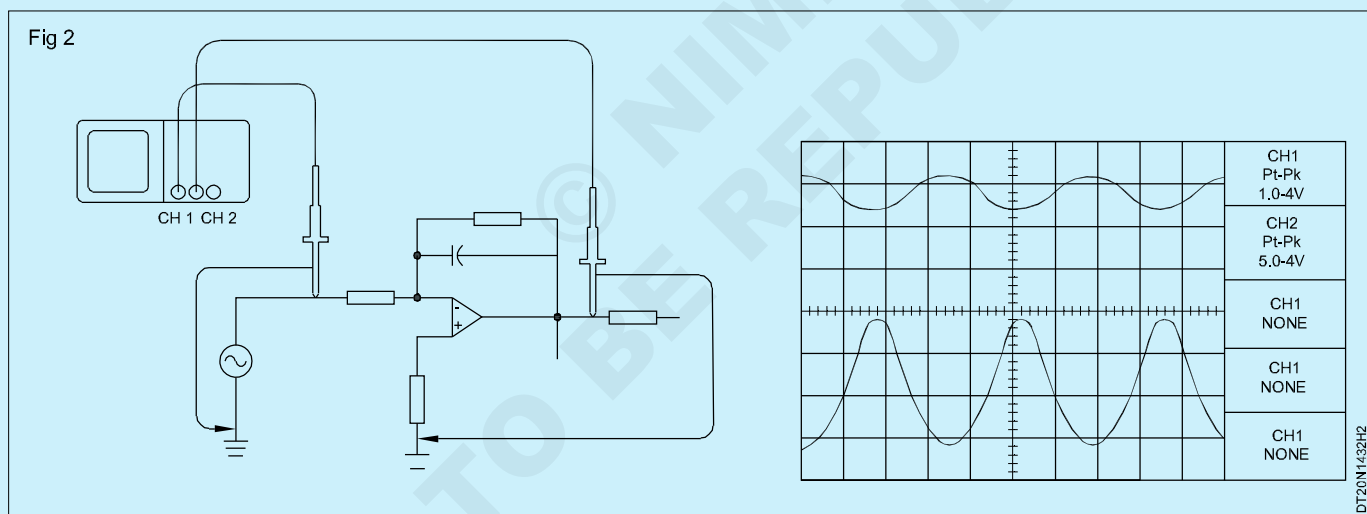

TASK 3: Measure the Ring Frequency

- 1 To measure the ring frequency at the rising edge of a signal, push the CURSOR button to see the Cursor Menu as in Fig 3.
- 2 Push the Type option button and select Time.
- 3 Push the Source option button and select CH1.
- 4 Turn the CURSOR 1 knob to place a cursor on the first peak of the ring.
- 5 Turn the CURSOR 2 knob to place a cursor on the second peak of the ring.
- 6 Observe that the delta time and frequency (the measured ring frequency) in the Cursor Menu.

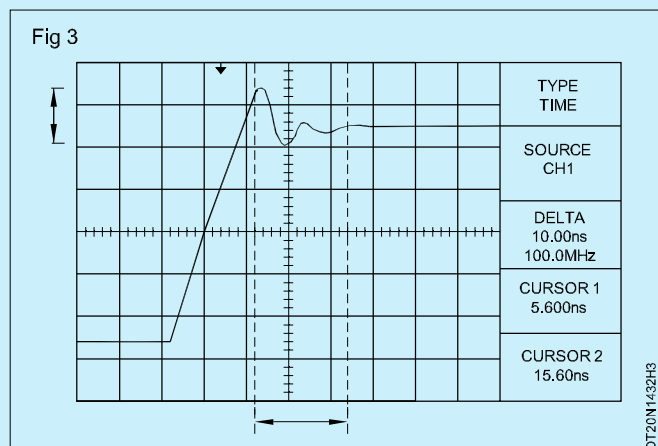

TASK 4: Measure the ring amplitude

- 1 To measure the amplitude of the ringing. To measure the amplitude, push the CURSOR button to see the Cursor Menu as in Fig 4.
- 2 Push the Type option button and select Voltage.
- 3 Push the Source option button and select CH1.3.
- 4 Turn the CURSOR 1 knob to place a cursor on the highest peak of the ring.
- 5 Turn the CURSOR 2 knob to place a cursor on the lowest point of the ring.
- 6 You can see the following measurements in the Cursor Menu:
 - The delta voltage (peak-to-peak voltage of the ringing)
 - The voltage at Cursor 1.
 - The voltage at Cursor 2

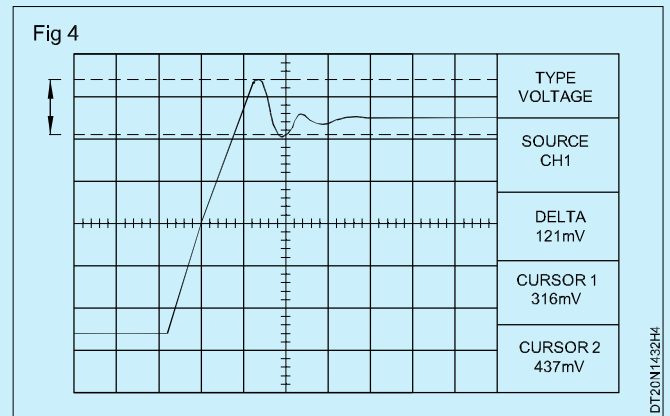

TASK 5 : Measure the pulse width

- 1 To measure the width of a pulse using the time cursors, push the CURSOR button to see the Cursor Menu as in Fig 5
- 2 LEDs light under the VERTICAL POSITION knobs to indicate the alternative CURSOR 1 and CURSOR 2 functions
- 3 Push the Source option button and select CH1.
- 4 Push the Type option button and select Time.
- 5 Turn the CURSOR 1 knob to place a cursor on the rising edge of the pulse.
- 6 Turn the CURSOR 2 knob to place the remaining cursor on the falling edge of the pulse.
- 7 Observe the following measurements in the Cursor Menu:
 - The time at Cursor 1, relative to the trigger.
 - The time at Cursor 2, relative to the trigger.
 - The delta time, which is the pulse width measurement

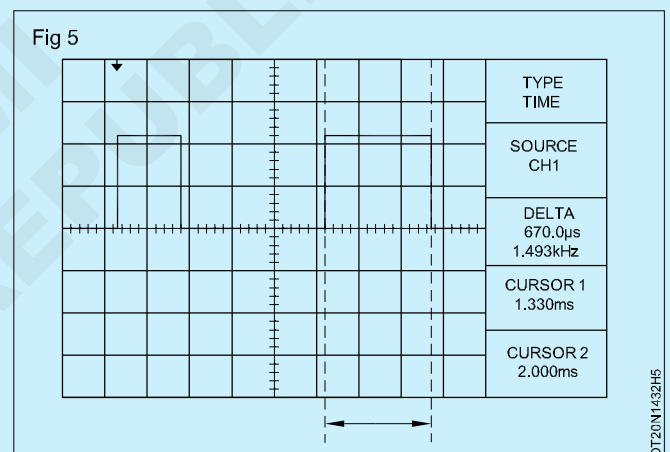

Note:

The Positive Width measurement is available as an automatic measurement in the Measure Menu.

The Positive Width measurement also displays when you select the Single-Cycle Square option in the AUTOSSET

TASK 6: Measuring rise time

- 1 Turn the SEC/DIV knob to display the rising edge of the waveform.
- 2 Turn the VOLTS/DIV and VERTICAL POSITION knobs to set the waveform amplitude to about five divisions.
- 3 Push the CH 1 MENU button to see the CH1 Menu if it is not displayed.
- 4 Push the Volts/Div option button and select Fine.
- 5 Turn the VOLTS/DIV knob to set the waveform amplitude to exactly five divisions..
- 6 Turn the VERTICAL POSITION knob to center the waveform position the baseline of the waveform 2.5 divisions below the center graticule.
- 7 Push the CURSOR button to see the Cursor Menu.
- 8 Push the Type option button and select Time.
- 9 Turn the CURSOR 1 knob to place the cursor at the point where the waveform crosses the second graticule line below center screen. This is the 10% level of the waveform as in Fig. 6.
- 10 Turn the CURSOR 2 knob to place the second cursor at the point where the waveform crosses the second graticule line above center screen. This is the 90% level of the waveform.

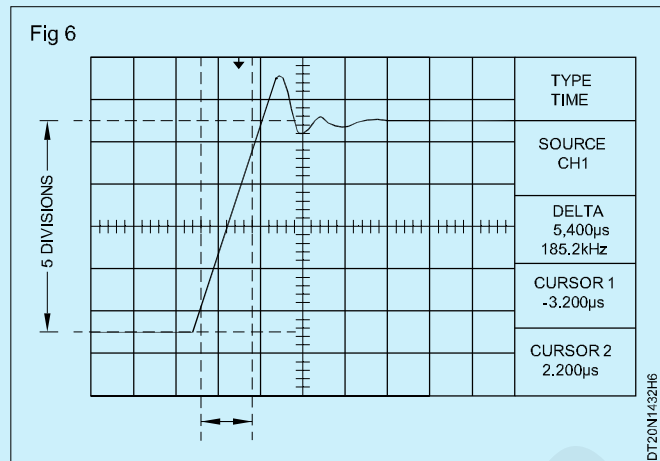

- 11 The Delta readout in the Cursor Menu is the rise time of the waveform.

Note :

The Rise Time measurement is available as an automatic measurement in the Measure Menu.

The Rise Time measurement also displays when you select the Rising Edge option in the AUTOSSET Menu.

Drone Technician - Measure Different Type Electrical Parameters and Record The Data Related with Drone Hardware

Measure the frequency and level of RF signals using of spectrum analyzer

Objective: At the end of this exercise you shall be able to

- measurement of frequency of spectrum analyzer.

Requirements		
Tools/Equipments/Instruments		
• Digital Multimeter with probes	- 1 Set	• 3GHz Spectrum Analyzer with built-in Tracking Generator - 1No.

PROCEDURE

Measurement of the frequency and level of RF signals

- 1 Prepare the spectrum analyzer for measurements and connect it
- 2 Observe the waveform, measure the frequency of oscillation and record it in Table 1.
- 3 Observe the of Level of RF signals and record in Table 1.

Table 1

Wave form	Calculated frequency (PRF)	Measured frequency (PRF)	Status of LED	Remarks

Practice function generator and Arbitrary Waveform Generator

Objective: At the end of this exercise you shall be able to
 • practice function generator and Arbitrary Waveform Generator.

Requirements	
Tools/Equipments/Instruments	
<ul style="list-style-type: none"> 25 MHz Arbitrary Waveform Generator with Digital Display for Frequency and Amplitude 	- 1 No.

PROCEDURE

Use the oscilloscope to measure the output voltage of the function generator.

- 1 Construct the Function generator circuit by referring to the circuit as shown in Fig 1
- 2 Connect a power supply to the circuit, set the voltage at 15V and switch on the power supply
- 3 Switch on the DSO and perform quick check
- 4 Connect the DSO probes at any one of the output terminal and ground, trace the waveform
- 5 Measure the frequency and record the reading in Table 1.
- 6 Repeat the step 4 and 5 for other output terminals.
- 7 Calculate the frequency using the formula $(f) = 0.15 / (VR1 + R1) C1$
- 8 Vary the C1 as shown in the table 2 and repeat steps 5 to 8
- 9 Compare the measured frequency and calculated frequency.

- 10 Get the work checked by the instructor.

Note: to get different frequencies the capacitor c1 may be varied, the Table 1 shown below gives the different frequency range for the different capacitor values.

Table 2

Frequency range	C ₁ value
1Hz - 100Hz	1µF
100Hz-1kHz	0.1µF
1kHz-10kHz	0.01µF
10kHz-100kHz	0.001µF

Table 1

Type of wave form	Calculated frequency	Measured frequency	Amplitude (P-P)
Sine wave			
Square wave			
Triangular wave			

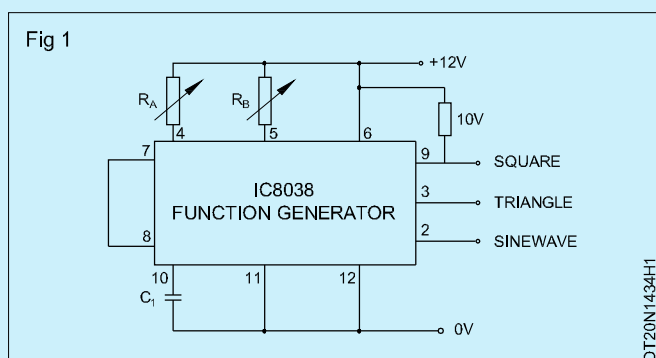

Identify different type of batteries Li-ion and Li-Po

Objectives: At the end of this exercise you shall be able to

- identification of battery Li-ion
- identification of battery Li-Po.

Requirements
Tools/Equipments/Instruments
• Lipo Battery and Li-ion - 1 Set

PROCEDURE

Identification of different type of batteries Li-ion and Li-Po.

- 1 The trainee takes li-ion battery and measure its voltage it should lie between 3.6-4.1 V
- 2 The trainee takes Li-Po battery and measure its voltage it should lie between 3.7-4.2 V

Instructor should provide both batteries in lab



Drone Technician - Identification of Different Type of Batteries, Battery Specifications and their Charging Techniques used in Drone

Record and recognize different battery specifications

Objectives: At the end of this exercise you shall be able to

- record data of different battery specifications
- make battery specifications
- identify battery specifications.

Requirements
Tools/Equipments/Instruments • Battery - 1 No.

PROCEDURE

Identification of different type of batteries Li-ion and Li-Po.

- | | |
|---|--|
| 1 The trainee takes li-ion battery and note down its specification in table 1.

2 Take another battery and note their specification in table 1. | 3 Repeat the same step for remaining batteries and fill the table

4 After writing their specification, compare specification of both the batteries

5 Get it corrected by the instructor. |
|---|--|

Check battery label

Table 1

S.No	Parameters	NiCad	NiMH	Lead Acid	Li-Ion	Li-Polymer	Rechargeable Alkaline
1	Capacity						
2	Temperature range usage						
3	Usable voltage range						
4	Charging duration						
5	Energy density						
6	Cost						
7	Impedance						
8	Flexibility						
9	Charge temperature						
10	Aging						
11	Weight						
12	Storage temperature						
13	Life span						
14	Safety/Explosive risk						

Drone Technician - Identification of Different Type of Batteries, Battery Specifications and their Charging Techniques used in Drone

Explore different charging techniques to charge batteries

Objectives: At the end of this exercise you shall be able to

- practice the charging techniques to charge batteries
- determine charging techniques.

Requirements			
Tools/Equipments/Instruments			
• Charger	- 1 No.	• Charge Controller training system	- 1 No.

Charging Methods

There are three common methods of charging a battery:

- Constant voltage.
- Constant current.

- Combination of constant voltage/constant current.

Instructor explain trainee about the battery charging process

PROCEDURE

TASK 1 : Perform constant voltage charging.

- | | |
|--|--|
| 1 Trainee take the charger | 3 Perform the Constant voltage charging |
| 2 Set the pre-set voltage values in it | 4 Instructor should check the work done by the trainee |

TASK 2 : Perform constant current charging.

- | | |
|--|--|
| 1 Trainee take the charger | 3 Perform the Constant current charging |
| 2 Set the current level at approximately 10% of the maximum battery rating | 4 Instructor should check the work done by the trainee |

TASK 3 : Perform Constant voltage / constant current charging

- | | |
|--|--|
| 1 Trainee take the charger | 3 Perform the Constant voltage / constant current charging |
| 2 Set the pre-set current level and a pre-set voltage level. | 4 Instructor should check the work done by the trainee |

Drone Technician - Identification of Different Type of Batteries, Battery Specifications and their Charging Techniques used in Drone

Measure and record different parameters of batteries using Battery management platform

Objectives: At the end of this exercise you shall be able to

- measure different parameters of batteries using Battery management platform
- record data of different parameters of batteries using Battery management platform.

Requirements	
Tools/Equipments/Instruments	
<ul style="list-style-type: none"> • Drone Battery Management Training Systems 	- 1 Set

PROCEDURE

Battery Parameters.

- 1 Trainee take the battery.
- 2 Use Battery management platform and start measuring battery parameters.
- 3 Measure the different parameters of batteries and fill the table 1.
- 4 Get it checked with your instructor.

Table 1

S.No.	Parameters of Batteries	Record Value
1	It determines for number of hours for which the battery can be discharged at a constant current to a defined cut-off voltage.	
2	Energy Density	
3	Specific Power	
4	Cell Voltage	
5	Charge and Discharge Current	
6	State of Charge	
7	Depth of Discharge	
8	Cycle Life	
9	Self-discharge	
10	Round-Trip Efficiency	

Drone Technician - Identification of Different Type of Batteries, Battery Specifications and their Charging Techniques used in Drone

Inspect battery packs faults for bulges or leakage

Objectives: At the end of this exercise you shall be able to

- carryout inspection of battery.
- check battery packs faults.

Requirements	
Tools/Equipments/Instruments	
• Battery	- 1 No.

PROCEDURE

Perform Inspect battery packs.

- 1 Carry out the visual inspection of the battery with the help of magnifying glass.
- 2 Identify if any bulges or leakage are seen.
- 3 The identified fault and get the work checked by the instructor.

Write Conclusion after inspection

Fig 1



Drone Technician - Identification of Different Type of Batteries, Battery Specifications and their Charging Techniques used in Drone

Identify fault related with chargers such as visible damage, voltage and current

Objective: At the end of this exercise you shall be able to

- Identification of charger fault.

Requirements	
Tools/Equipments/Instruments	
• Battery Charger	- 1 No.
• Multimeter	- 1 No.

PROCEDURE

Perform Inspect chargers packs.

- 1 Carry out the visual inspection of the chargers.
- 2 Identify if any visible damage is seen.
- 3 Check its voltage and current.
- 4 Identified fault and get the work checked by the instructor.

Write Conclusion after inspection



Drone Technician - Identification of Different Type of Batteries, Battery Specifications and their Charging Techniques used in Drone

Measure and record different parameters of charging controller using software

Objectives: At the end of this exercise you shall be able to

- **measure different parameters of charging controller using software**
- **record different parameters of charging controller using software.**

Requirements	
Tools/Equipments/Instruments	
• Charger	- 1 No.
• Charge controller training system	- 1 No.

PROCEDURE

Measurement and record chargers controller parameters.

- 1 Connect the Fuse to the Positive Battery Cable
- 2 Connect the Battery Cables to the Charge Controller
- 3 Connect the Battery Cables to the Battery
- 4 Note and Write the Technical Specifications in Table 1.

Table 1

S.No	Parameters	Specifications
1		
2		
3		
4		
5		

Check out the wiring diagram manual to see how to connect a battery to a charge controller

Drone Technician - Identification of Different Type of Batteries, Battery Specifications and their Charging Techniques used in Drone

Calculate maximum discharge and battery capacities in order calculate flight time

Objectives: At the end of this exercise you shall be able to

- calculate maximum discharge
- calculate battery capacities
- calculate flight time.

Requirements	
Tools/Equipments/Instruments	
• Battery	- 1 No.

PROCEDURE

Step 1 : Calculate the maximum discharge using the formula

Use capacity of a LiPo is only 80% of your total amp-hours.

maximum discharge = battery capacity (Ah) X 0.8.

Step 2 : Calculate the battery's capacity and convert into amp-hours using the formula

battery capacity in (Ah)= battery capacity in (mAh)/ 1000.

Record the calculation and result in Table 1.

Step 3 : calculation Flight time

- 1 Note battery capacity in amp-hours from step 1 and multiply by battery discharge in amps from step 2.
- 2 Divide by average amp draw in amps.
- 3 Multiply by 60 to total flight time in minutes.

The Formula

Flight time = (Battery Capacity x Battery Discharge / Average Amp Draw) x60

Calculate the values with other battery specification and find flight time

Note down and compare the calculated values with the others values.

Get the work checked by the instructor.

Table 1

S.No	Maximum Discharge	Battery Capacity	Flight time
1			
2			
3			
4			

Drone Technician - Identify & Select Different Types of Drones, Drone Rules and Regulations, Drone Applications, and Important Safety Precautions

Identify and measure condition of drone sensors

Objectives: At the end of this exercise you shall be able to

- identify condition of drone sensors
- measurement condition of drone sensors
- observe different sensors.

Requirements	
Tools/Equipments/Instruments	
• Drone Sensor Trainer Kit	- 2 Nos.

PROCEDURE

Identify condition of drone sensors

- 1 Collect all the different sensor
- 2 Identify the condition of Sensor
- 3 Test sensor by connecting battery with them and compare its values.

Instructor should arrange all sensors

- 4 Fill the details in the table 1

Table 1

S.No.	Sensor	Difference between the Estimated Position and the Actual One
1	Camera,	
2	IMU, Optical, GNSS, UWB	
3	WiFi	
4	Stereo Vision	
5	UWB, RGBD Sensor	
6	Infrared, IMU, computer vision	

Explore different converters like V/I, I/V, F/V, V/F

Objectives: At the end of this exercise you shall be able to

- make different converters circuit diagram
- determine different converters.

PROCEDURE

TASK 1: Voltage to Current Converter.

A voltage to current converter is an electronic circuit that takes current as the input and produces voltage as the output.

Trainee should note down following things about V to I convertor.

Instructor should explain circuit diagram to trainee.

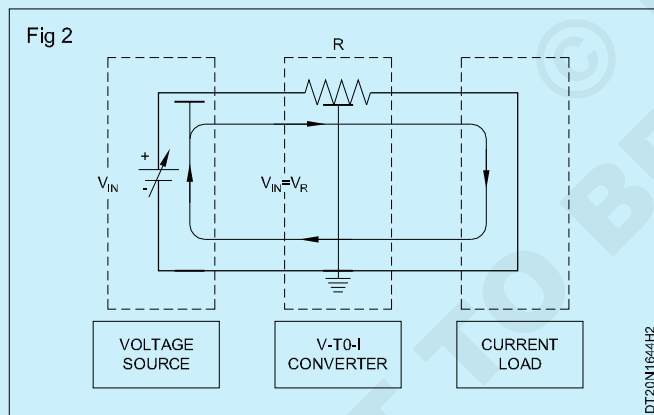
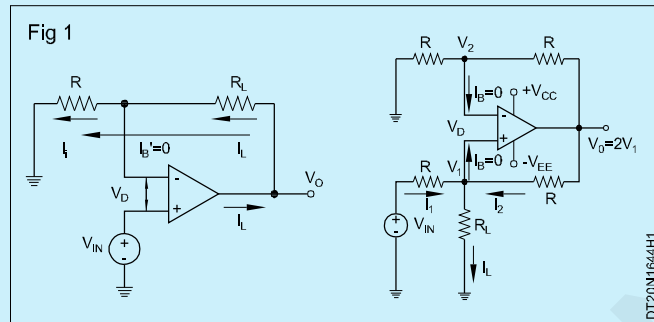

Table 1

S.No		Reason
1	But why would we do this?	
2	Which current is preferable	
3	Purpose Voltage to Current Converters	
4	Nodal equation	

TASK 2: Current to Voltage Converter.

A current to voltage converter or I to V converter is an electronic circuit that takes current as the input and produces voltage as the output.

Instructor should explain circuit diagram to trainee

Trainee should note down following things about V to I convertor.

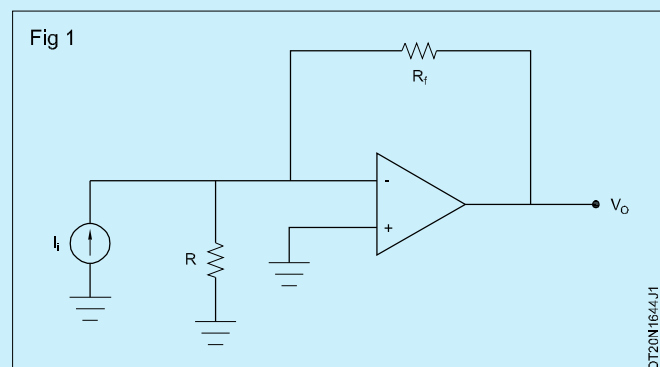

Table 2

S.No		Reason
1	But why would we do this?	
2	Which current is preferable	
3	Purpose Current to Voltage Converters	
4	Nodal equation	

TASK 3: Frequency to Voltage Converter.

Frequency to voltage converter is an electronic device which converts the sinusoidal input frequency into a proportional current or output voltage.

Table 1

S.No		Write
1	Specifications	
2	Features	
3	Applications	

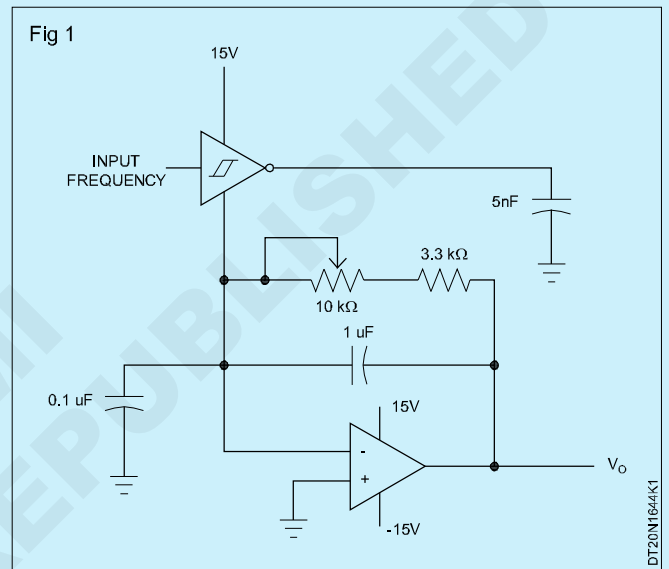

TASK 4: Voltage to Frequency Converter.

Voltage of frequency converters also called wide range voltage controlled oscillator may be a component or electronic circuit which converts an input voltage to a linear or non linear frequency output. voltage to frequency converter.

Table 2

S.No		Write
1	Specifications	
2	Features	
3	Applications	

Verify frequency response of low pass and high pass filters

Objectives: At the end of this exercise you shall be able to

- construct low pass and high pass filters
- verify frequency response of low pass and high pass filters.

Requirements

Tools/Instruments/Materials

- ADALM1000 hardware module - 1 No.
- Resistors (1 k Ω) X Capacitor (1 μ F) X Inductor (20 mH)

PROCEDURE

Low-Pass RC Filter.

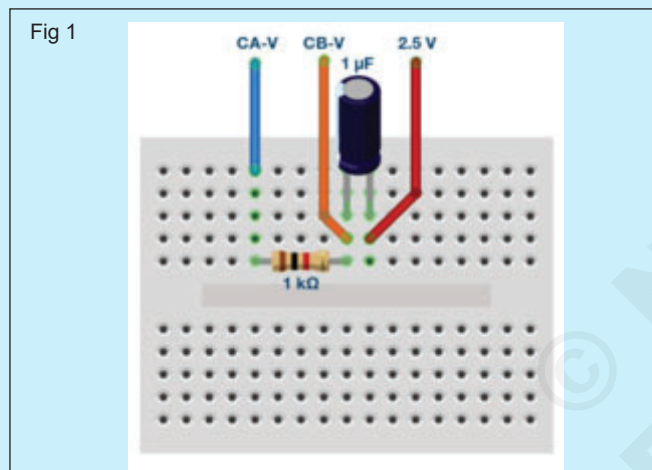

- 1 Set up the RC circuit as shown in Figure 1 on your solderless bread-board, with the component values $R_1 = 1\text{ k}\Omega$, $C_1 = 1\mu\text{F}$.
- 2 Set the Channel A AWG min value to 0.5V and max value to 4.5V to apply a 4V p-p sine wave centred on 5V as the input voltage to the circuit. From the AWG A Mode drop-down menu, select SVM1 mode. From the AWG A Shape drop-down menu, select Sine. From the AWG B Mode drop-down menu, select the Hi-Z mode.
- 3 From the ALICE Curves drop-down menu, select CA-V and CB-V for From the Trigger drop-down menu, select CA-V and Auto Level. Set the Hold Off to 2 (ms). Adjust the time base until you have approximately two cycles of the sine wave on the display grid. From the Meas CA drop-down menu, select P-P under CA-V and do the same for CB. Also, from the Meas CA menu, select A-B Phase.
- 4 Start with a low frequency, 50Hz, and measure output voltage CB-V peak to peak from the scope screen. It should be the same as the channel A output. Increase the frequency of Channel A in small

increments until the peak-to-peak voltage of Channel B is roughly 0.7 times the peak-to-peak voltage for Channel A. Compute 70% of V p-p and obtain the frequency at which this happens on the oscilloscope. This gives the cut-off (roll-off) frequency for the constructed low-pass RC.

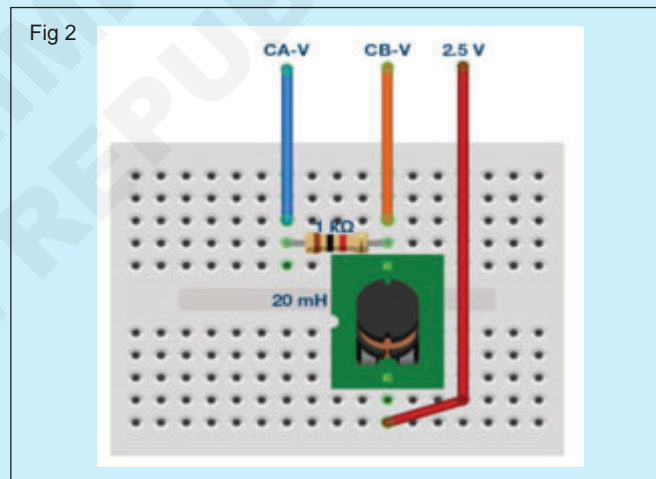

High-pass RL filter

- 1 Set up the RL circuit as shown in Figure 2 on your solderless bread-board, with the component values $R_1 = 1\text{ k}\Omega$, $L = 20$
- 2 Repeat Steps 2 and 3, as in part A, to obtain the oscilloscope.
- 3 Start with a high frequency, 20 kHz, and measure output voltage CB-V peak to peak from the scope screen. It should be the same as the Channel A Lower the frequency of Channel A in small increments until the peak-to-peak voltage of Channel B is roughly 0.7 times the peak-to-peak voltage for Channel A. Compute 70% of V p-p and obtain the frequency at which this happens on the oscilloscope. This gives the cut-off (roll-off) frequency for the constructed high-pass RL filter.

Drone Technician - Identify & Select Different Types of Drones, Drone Rules and Regulations, Drone Applications, and Important Safety Precautions

Test and measure different amplifier functions

Objectives: At the end of this exercise you shall be able to

- **test different amplifier functions**
- **measure different amplifier functions.**

PROCEDURE

Test different amplifier functions.

- | | |
|--|--|
| <p>1 The first step is to take wires from the output terminals of amplifier.</p> <p>2 set the multimeter to AC voltage ranging between 10 – 100VAC</p> | <p>3 Place Multimeter Probes on Amplifier Output Terminals</p> <p>4 Apply A Test Frequency</p> <p>5 Evaluate Results</p> |
|--|--|

S.No	Measured value of watt	Voltage

© NIMI
 NOT TO BE REPRODUCED

Drone Technician - Identify & Select Different Types of Drones, Drone Rules and Regulations, Drone Applications, and Important Safety Precautions

Measure and record the resistance, voltage, current and frequency of different sensors used in drone

Objectives: At the end of this exercise you shall be able to

- observe different sensor values used in drone
- measure sensor values
- record sensor values.

Requirements	
Tools/Equipments/Instruments	
• Sensor	- 1 No.

PROCEDURE

Measure and record the values of different sensors used in drone.

- 1 Collect all the different sensor.
- 2 Make sensor activate by connecting battery with them.
- 3 Note down the values in table 1.
- 4 Fill the details in the table 1.

Instructor should arrange all sensors

Table 1

S.No	Parameters	Record values
	Resistance	
	Voltage	
	Current	
	Frequency	

Drone Technician - Identify & Select Different Types of Drones, Drone Rules and Regulations, Drone Applications, and Important Safety Precautions

Test & measure accelerometers, inertial measurement units, tilt and lidar sensor, gyro sensor

Objectives: At the end of this exercise you shall be able to

- test accelerometers, inertial measurement units, tilt and lidar sensor, gyro sensor
- measure accelerometers, inertial measurement units, tilt and lidar sensor, gyro sensor.

Requirements			
Tools/Equipments/Instruments			
• IMU	- 2 No.	• Atmospheric pressure	- 2 No.
• Accelerometer	- 2 No.	• Gyro	- 2 No.

PROCEDURE

Test & measure accelerometers, inertial measurement units, tilt and lidar sensor, gyro sensor

- 1 Go to drone App
- 2 Select option accelerometers
- 3 Test & measure Accelerometer data
- 4 Next go to IMU option in the App and note down the IMU data
- 5 Repeats the steps for remaining sensor
- 6 Fill table 1 and get corrected by the instructor

Gyro Characteristics	Value	Accelerometer characteristics	Value
Range Roll,Pich.Yaw (°/Sec)		Range X,Y,Z (g)	
Bias Roll, Pich,Yaw (°/Sec)		Bias X,Y,Z (mg)	
Scale Factor Accuracy (%)		Factor Accuracy (%)	
Non - Linearity(%FS)		Non - Linearity (%FS)	
Resolution (°/Sec)		Resolution (mg)	
Bandwidth (Hz)		Bandwidth (Hz)	
Random walk (° /hr ^{1/2})		Random walk (m/s/hr ^{1/2})	

Drone Technician - Identify & Select Different Types of Drones, Drone Rules and Regulations, Drone Applications, and Important Safety Precautions

Write and upload computer code to FCB to test sensors results

Objectives: At the end of this exercise you shall be able to

- create computer code
- run computer code
- test computer code.

Requirements	
Tools/Equipments/Instruments	
• Laptop latest configuration	- 1 No.
• FCB (Flight Controller Board)	- 1 No.
• Drone Sensor	- 1 No.

PROCEDURE

Write Computer Code upload code to an FCB.

- 1 Install programming software on your computer/ laptop
- 2 Connect the FCB to your PC using a USB cable and wait for Windows to begin the USB driver installation process.
- 3 Go to Device Manager from Start→ Control Panel option and find the COM Ports of your driver.
- 4 Choose the correct serial COM port for your board. The COM port number will be visible under the Device Manager.
- 5 Open the source code/sketch, compile it and upload the code to the FCB board by clicking the Upload button.
- 6 Compile the sensor code and upload it to the FCB board.
- 7 Test the sensors results and fill in table 1

Table 1

S.No	Estimated Position	Actual One
1		
2		
3		
4		
5		
6		
7		

Drone Technician - Identify & Select Different Types of Drones, Drone Rules and Regulations, Drone Applications, and Important Safety Precautions

Calibrate the compass, Lidar, and gyro sensor

Objectives: At the end of this exercise you shall be able to

- calibrate the compass
- calibrate Lidar
- calibrate gyro sensor.

Requirements	
Tools/Equipments/Instruments	
• Drone with compass	- 1 No.
• Lidar	- 1 No.
• Gyro Sensor	- 1 No.

PROCEDURE

TASK 1: Calibrate Compass Calibration.

- | | |
|--|---|
| <ol style="list-style-type: none"> 1 Start software and connect the drone. 2 Click the Compass sensor button. 3 Click OK to start the calibration. 4 Place the drone in flat plate 5 Follow the instruction which is coming on screen | <ol style="list-style-type: none"> 6 Rotate the drone around the specified axis in either/ both directions. 7 Once the calibration is complete a green colour light will blink. 8 Software will display Calibration complete |
|--|---|

TASK 2: Calibrate Lidar Calibration

- | | |
|---|--|
| <ol style="list-style-type: none"> 1. Connect the LiDAR 2. Connect the camera | <ol style="list-style-type: none"> 3. Collect the photo and LiDAR data 4. Calibration data acquisition |
|---|--|

TASK 3: Gyroscope Calibration.

- | | |
|--|---|
| <ol style="list-style-type: none"> 1 Click the Gyroscope sensor button 2 Place the vehicle on a surface and leave it still. 3 Click Ok to start the calibration. 4 Place the drone in flat plate 5 Follow the instruction which is coming on screen | <ol style="list-style-type: none"> 6 Once the calibration is complete a green colour light will blink. 7 Software will display Calibration complete |
|--|---|

Fill the Table 1 with your data

Table 1

S.No	Parameters	Before Calibration	After calibration
1			
2			
3			
4			
5			

Drone Technician - Identify & Select Different Types of Drones, Drone Rules and Regulations, Drone Applications, and Important Safety Precautions

Measure and record angular rate, force, and magnetic field through IMU

Objectives: At the end of this exercise you shall be able to

- measurement of angular rate, force, and magnetic field through IMU
- record angular rate, force, and magnetic field through IMU

Requirements	
Tools/Equipments/Instruments	
• IMU	- 1 No.

PROCEDURE

Battery Parameters

- 1 Trainee take the IMU and connect it with battery
- 2 IMU combined with sensor fusion software, and determine motion, orientation and heading.
- 3 Record the values in the table 1
- 4 Get it checked with your instructor

S.No	Parameters	Measured Values
1	Motion	
2	Orientation	
3	Heading	

Construct and test various Op-Amp circuits Inverting, Non-inverting, Summing Amplifiers

Objectives : At the end of this exercise you shall be able to

- construct and test Inverting amplifier using LM 324
- construct and test Non-Inverting amplifier using LM 324
- construct and test summing amplifier and differential amplifier using LM 324.

Requirements	
Tools/Equipments/Instruments	Materials/Components
<ul style="list-style-type: none"> • Analog/Universal IC Tester with instruction manual - 1 No. • CRO, 20 MHz Dual trace - 2 Nos • Semiconductor Data book - 1 No. • Analog/Digital multimeter with probes - 1 No. • Dual regulated DC power supply 0-30V/2A - 1 No. • Function generator - 1 No. • Trainees tool kit - 1 Set 	<ul style="list-style-type: none"> • Op-Amp ICs LM324, UA741 - 2 Nos each • Breadboard - 2 Nos each • Resistors 10 kΩ, ¼ W/CR25 - 7 Nos • 100 kΩ, ¼ W/CR25 - 1 No. • Hook up wires/connecting wires - as reqd • IC base (8 pin), DIP - 2 Nos • Diodes 1N4001 - 4 Nos

PROCEDURE

TASK 1: Construction and testing of an inverting amplifier

- 1 Collect all the required components from the instructor and check them with multimeter; use IC tester for checking ICs.
- 2 Identify the type of package and pins of the given Op-Amp using Data book.
- 3 Refer to circuit diagram shown in Fig 1 and assemble the inverting amplifier circuit on bread board.
- 4 Get the assembled circuit checked by the Instructor.

Always keep an IC base fixed on the breadboard for inserting the Op-Amp IC.

- 5 Connect +12V, -12V and GND of dual DC power supply to pin 4, pin 11 and GND respectively.
- 6 Prepare the CRO for measurements and apply 0.2V_{p-p} at the input.
- 7 Measure the output using DMM and CRO.
- 8 Vary the input voltage and observe the output variations using multimeter and oscilloscope; record the observation in Table 1.
- 9 Change the value of feedback resistor R_F and R_{in} observe the variation in gain and record them in Table.
- 8 Get the completed work checked by the Instructor.

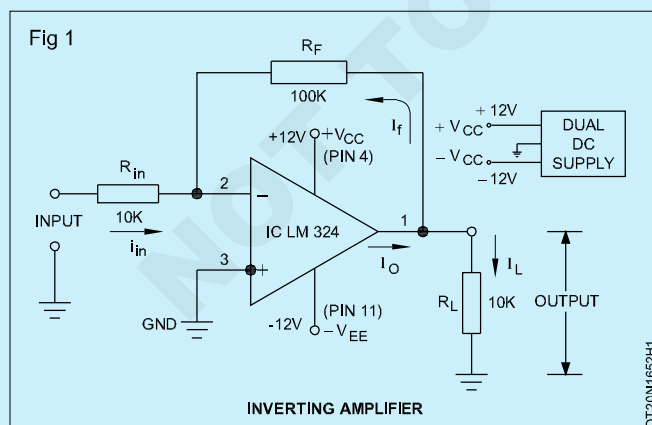

TASK 2: Construction and testing of a non-inverting amplifier using IC LM324

- 1 Refer to the circuit diagram shown in Fig 2 and modify the assembled circuit on Bread board.
- 2 Get the assembled circuit checked by the Instructor.
- 3 Repeat steps 5 to 8 of Task 1 and record the observations.
- 4 Repeat the steps 9, record the observations and calculate the gain and record them.
- 5 Get the work checked by the Instructor.

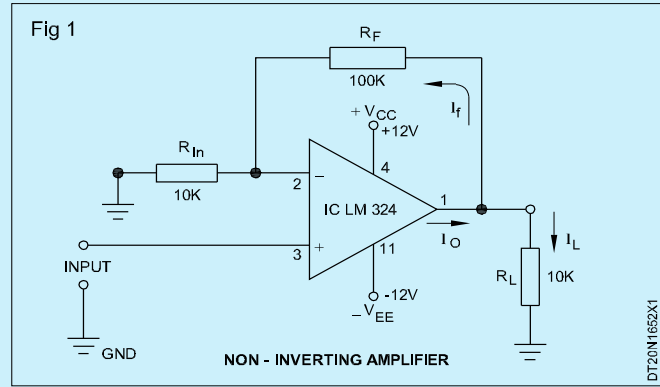

Table 1

Sl.No.	Input voltage applied (V_i)	Output voltage		Gain normal observed values V_{out} / V_{in}		Gain x Vin= Volt Calculate values	
		Inverting amplifier	Non inverting amplifier	Inverting amplifier	Non inverting amplifier	Inverting amplifier $(R_f/R_{in}) \times V_{in}$	Non inverting $(1+(R_f/R_{in})) \times V_{in}$
1	0.2V						
2	0.4V						
3	0.6V						

TASK 3: Construction and testing of a summing amplifier using IC LM324

Carry out the experiment on a Bread board. The suitable values for input voltage are kept such that.

$$\frac{R_F}{R_1} = \frac{R_F}{R_2} = \frac{R_F}{R_3} = \frac{R_f}{R_{in}}$$

- 1 Collect all the required items, check the components and assemble the circuit according to the amplifier circuit shown in Fig 3.

Note the inputs have been applied to inverting terminal.

- 2 Get the assembled circuit checked by the instructor.
- 3 Switch ON the dual DC power supply measure the output using multimeter and CRO.

Use the given formula to calculate the output voltage for summing amplifier.

- 4 Verify the results obtained & compare with the calculated values.

To apply inputs to noninverting terminal exchange the inputs applied on inverting and non inverting terminals.

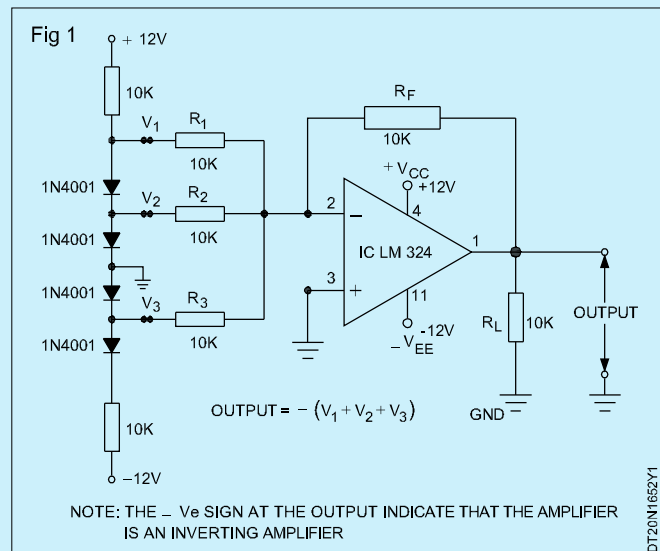

Observation table

Table 2

S.No.	Configuration	Output voltage	Result
1	When inputs V_1, V_2 & V_3 have been applied on -Ve terminal	$V_o =$	Is O/P proportional to sum of inputs? (Yes / No)
2	When input V_1, V_2 & V_3 have been applied on +Ve terminal	$V_o =$	Is output proportional to sum of inputs? (Yes / No)

Formula to calculate output voltage of summing amplifier

i For Inverting Amplifier

$$V_o = - \left(\left(\frac{R_f}{R_{in}} \times V_1 \right) + \left(\frac{R_f}{R_{in}} \times V_2 \right) + \left(\frac{R_f}{R_{in}} \times V_3 \right) \right) = \frac{R_f}{R_{in}} (V_1 + V_2 + V_3)$$

ii For Non-Inverting Amplifier

$$V_o = \left(\left(1 + \frac{R_f}{R_{in}} \right) V_1 + \left(1 + \frac{R_f}{R_{in}} \right) V_2 + \left(1 + \frac{R_f}{R_{in}} \right) V_3 \right) = \left(1 + \frac{R_f}{R_{in}} \right) (V_1 + V_2 + V_3)$$

If $R_f = R_1$

$$V_o = 2 (V_1 + V_2 + V_3)$$

TASK 4: Construction and testing of Differential Amplifier using LM324

- 1 Modify the components values and assemble the circuit shown in Fig 4.
- 2 Get the assembled circuit checked by the instructor.
- 3 Repeat step 5 of Task 1.
- 4 Apply the DC inputs to the differential amplifier circuit at pin 2 and pin 3 through 10k resistors as per the Table 3.
- 4 Measure the output using Multimeter and record in given table.
- 5 Change the input values at V1 and V2 and record the output readings in Table 3.
- 6 Compare the calculated value with observed.
- 7 Get the work checked by the Instructor.

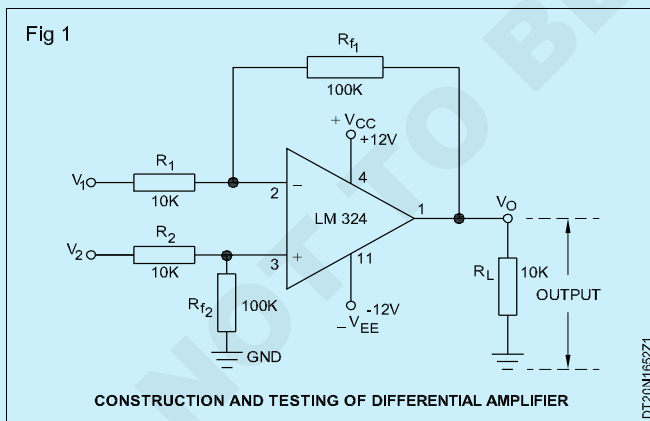

Note: A $R_{f1} = R_{f2} = R_f$ and $R_1 = R_2 = R_{in}$

$$V_o \text{ Output} = (V_2 - V_1) \frac{R_f}{R_{in}}$$

Observation table

Table 3

Input to Differential Amplifier		Output to (V_o) calculated	Output Observed (V_o)
V_1	V_2		
0.5V	1V		
+1V	-2V		
-2V	+2.5V		

Drone Technician - Identify, Select and Test Hardware Assembly, Driver for BLDC Motors

Identify different BLDC motors and their specifications

Objectives: At the end of this exercise you shall be able to

- select the BLDC Motor
- make specification of BLDC Motor.

Requirements
Tools/Equipments/Instruments <ul style="list-style-type: none"> • BLDC (Brushless DC) Motor Training System - 1 No.

PROCEDURE

Identify different BLDC motors used in drone

- 1 Pick any one of the BLDC motors
- 2 Identify the type of the BLDC motors.
- 3 Record the name and its specification in the table1.
- 4 Repeat above steps for all other BLDC motors and write in table 1.

S.No	Parameters	Measured Values
1	Number of Cells	
2	Kv	
3	Maximum Efficiency	
4	Maximum Efficiency Current in Amps	
5	No Load current	
6	Resistance in ohms	
7	Maximum Current in amps	
8	Maximum Watts	
9	Poles	

Drone Technician - Identify, Select and Test Hardware Assembly, Driver for BLDC Motors

Inspect and test BLDC Motor driver circuit

Objectives: At the end of this exercise you shall be able to

- check BLDC Motor driver circuit
- test BLDC Motor driver circuit.

Requirements	
Tools/Equipments/Instruments	
<ul style="list-style-type: none"> • BLDC (Brushless DC) Motor Training System - 1 No. 	<ul style="list-style-type: none"> • Lidar - 1 No. • Gyro Sensor - 1 No.

PROCEDURE

Inspect BLDC Motor driver circuit

- 1 Collect all the components, test them and refer to the pin out diagram of the IC and assemble the circuit as per the motor circuit diagram shown in Fig 1.
- 2 Get the assembled circuit checked by the instructor.
- 3 Set the inputs different values
- 4 Switch ON the power supply
- 5 Prepare the value for measurements and measure the output at the output pin and verify the practical values. (Fig 2)

Instructor should explain about circuit diagram

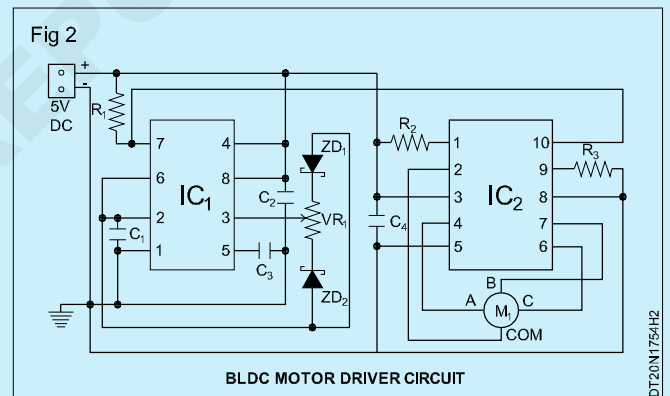
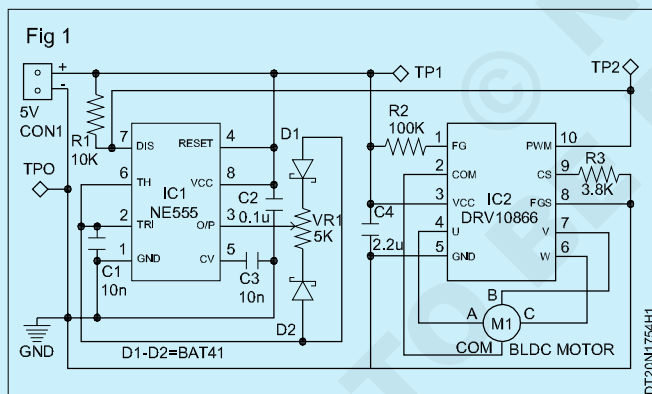

Measure and record speed-torque characteristics of BLDC Motor

Objectives: At the end of this exercise you shall be able to

- measure the speed-torque characteristics
- plot the speed-torque graph.

Requirements			
Tools/Equipments/Instruments			
• BLDC Motor	- 1 No.	• Transmitter and receiver	- 1 No.
• Battery	- 1 No.	• Esc	- 1 No.

PROCEDURE

Measurement speed-torque of BLDC Motor

- 1 Set the motor to measure a speed and torque.
- 2 Connect the motor with ESC and battery as shown in Figure 1.
- 3 Measure and record the readings shown by the meter in Table 1.
- 4 Change the throttle value to measure the different values.
- 5 Record Speed-Torque fill in the table 1
- 6 Trainee should draw the graph as per the data in table 1

Table 1

Motor Series	Motor Diameter	Applied voltage (volts)	Current (amps)	Torque	Speed

Draw the graph between Torque and Speed

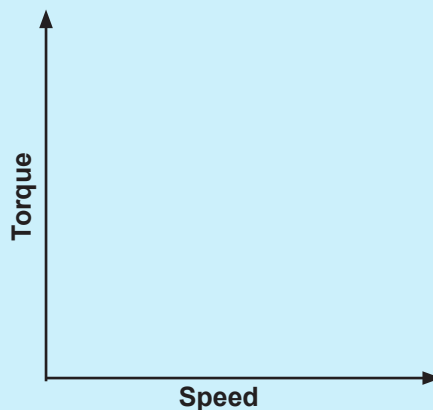

Explore driving circuit of DC, BLDC and servo motors

Objectives: At the end of this exercise you shall be able to

- make driving circuit of DC, BLDC and servo motors
- determine different driving circuit.

Requirements			
Tools/Equipments/Instruments			
• DC Motor	- 1 No.	• BLDC Motor	- 1 No.
		• Servo Motors	- 1 No.

PROCEDURE

TASK 1 : Driving Circuit of DC

Instructor explain about the circuit diagram

- 1 Make circuit connections on the lug board as per the schematic circuit in Fig 1.
- 2 Get the wired circuit checked by your instructor.

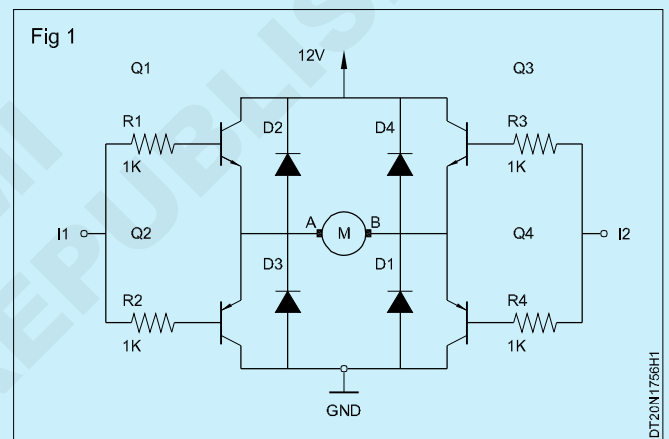

TASK 2 : Driving circuit of BLDC

- 1 Make circuit connections on the lug board as per the schematic circuit in Fig 1.
- 2 Get the wired circuit checked by your instructor.

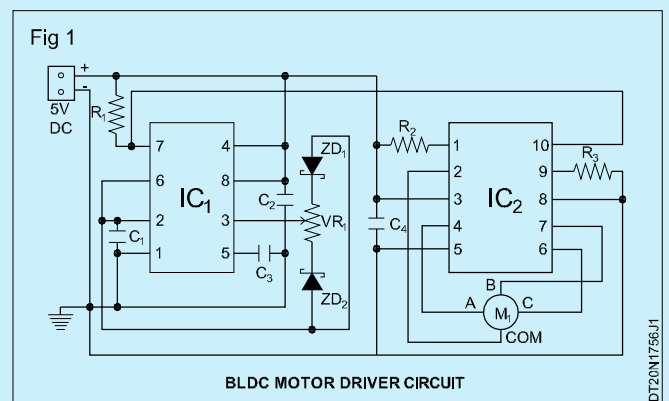

TASK 3 : Driving circuit of Servo Motor

- 1 Make circuit connections on the lug board as per the schematic circuit in Fig 3.
- 2 Get the wired circuit checked by your instructor.

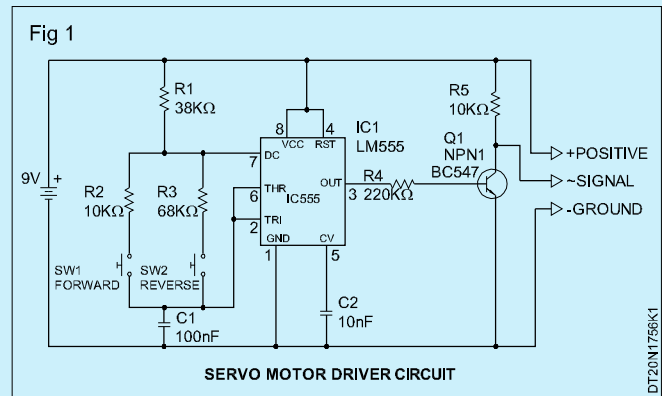

Perform running and reversing phenomenon of BLDC Motor

Objectives: At the end of this exercise you shall be able to

- perform running of BLDC Motor
- practice reversing phenomenon of BLDC Motor.

Requirements			
Tools/Equipments/Instruments			
• BLDC Motor	- 1 No.	• Battery	- 1 No.
		• ESC	- 1 No.

PROCEDURE

TASK 1: Running phenomenon of BLDC Motor

- 1 Actually BLDC is a AC driven motor,the AC pulses(Phase A,Phase B,Phase C) are generated from an inverter circuitry whose source is a DC power supply(+ve and -ve DC rails). Hence the name BLDC motor.
- 2 So in order to change the rotation of BLDC motor you just need to interchange any two of the three phases mentioned above.
- 3 But in your case, those two wires appears to be the +ve and -ve DC rails. The inverter circuit comes after

the DC power section. So you need first find the inverter section of your BLDC driver and then find the three phase wires. After that you can interchange any two phases to change the direction of the motor.

(Note: Many BLDC motor, for eg. the DC fan on desktop CPU comes with inbuilt inverter under the outrunner, with only positive and negative wires coming out, so all we need is to give a DC supply to make it run.)

TASK 2: Reversing phenomenon of BLDC Motor

- 1 BLDC is an AC driven motor, the AC pulses (Phase A, Phase B, Phase C) are generated from an inverter circuitry whose source is a DC power supply (+ve and -ve DC rails).
- 2 interchange any two of the three phases
- 3 check the rotation of BLDC motor

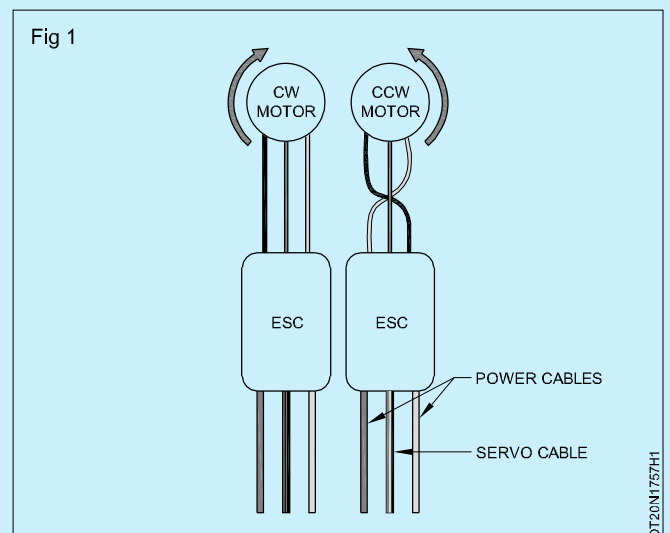

Demonstration speed control of BLDC Motor using PWM technique

Objectives: At the end of this exercise you shall be able to

- demonstration of speed control of BLDC Motor using PWM technique
- set up speed control of BLDC Motor using PWM technique.

Requirements	
Tools/Equipments/Instruments	
<ul style="list-style-type: none"> • BLDC (Brushless DC) Motor Training System 	- 1 No.

PROCEDURE

Demonstration of speed control of BLDC Motor using PWM technique

- 1 Observe the BLDC Motor
- 2 The instructor has to demonstrate the controls of BLDC Motor using PWM technique

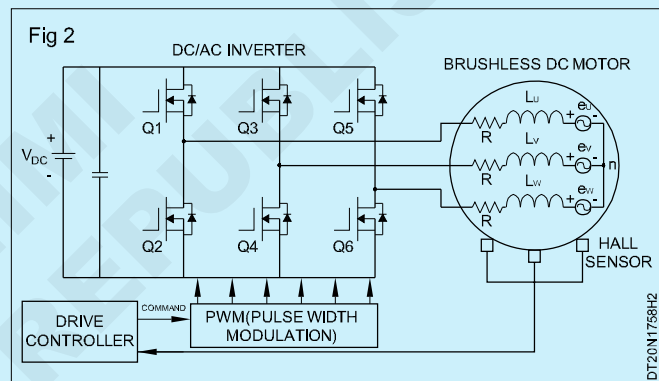
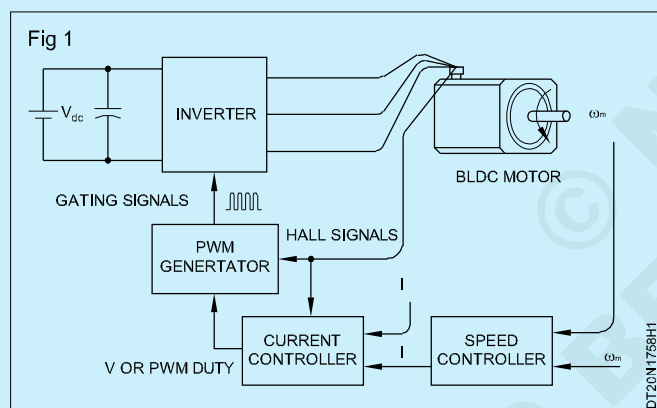

- 3 The instructor has to arrange a speed control of BLDC Motor using PWM technique
- 4 Get the recorded details of the devices checked by the instructor.

Practice Inverted pendulum balancing using programming technique and PID tuning

Objectives: At the end of this exercise you shall be able to

- practice Inverted pendulum balancing using programming technique
- practice PID tuning

Requirements	
Tools/Equipments/Instruments	
• Inverted pendulum	- 1No.
• Laptop	- 1No.

PROCEDURE

Parameters of the inverted pendulum

- Collect all the parts
- Assembling the Gantry Rollers, Motor, Idle Pulley)
- Assembling the Pendulum
- Mounting the Pendulum and Belts
- Wiring and Electronics
- Controlling the System (Proportional Control)
- Controlling the System (PID Control)
- Check the Final Results

Write the Parameters of the inverted pendulum in Table 1.

Table 1

M	mass of the cart	
m	mass of the pendulum	
b	friction of the cart	
l	length of the pendulum	
i	inertia of the pendulum	
f	force applied to the cart	
g	gravity	
θ	Vertical pendulum angle	

Inverted Pendulum with PID Control Model

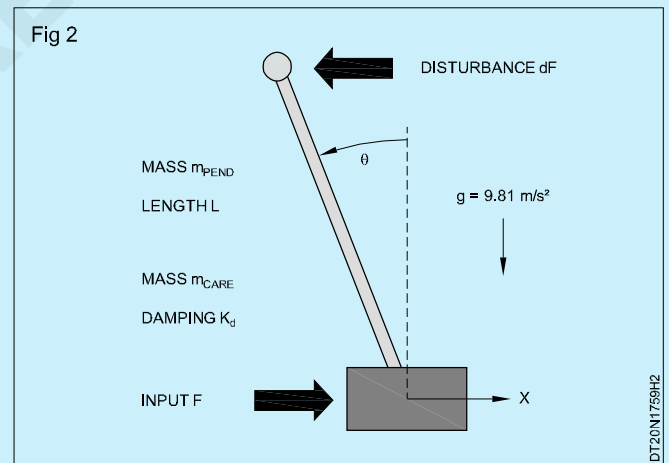
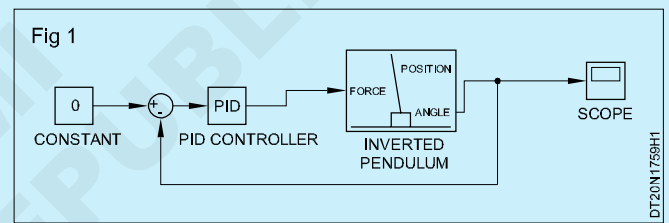

Table 2

S.No	Angle	Error
1		
2		
3		
4		
5		

Measure thrust to weight ratio and payload

Objectives: At the end of this exercise you shall be able to

- determine thrust to weight ratio
- calculate the motor ratings
- calculate thrust to weight ratio
- use simple formula for calculations.

Requirements			
Tools/Equipments/Instruments			
• Thrust measurement meter	- 1No.	• FCB (Flight Controller Board)	- 1No.
• Propellers- 1No.	- 1No.	• Lipo Battery and Charger	- 1No.
• Frame	- 1No.	• RF Transmitter and receiver	- 1No.
• BLDC Motors	- 1No.		
• ESC (Electronic Speed controllers)	- 1No.		

PROCEDURE

TASK 1: Payload calculation

Use the formula and calculate other payload possibility which drone can carry

Formula to calculate Payload

Payload = AUW - Drone Weight

Fill the table and show it to the instructor - Table 1

S.No	AUW	DRONE WEIGHT	PAYLOAD
1			
2			
3			
4			

TASK 2: Thrust to weight calculation

Determine the optimal thrust of the drone motor the most important parameter is the thrust to weight ratio.

Calculate the weight and note down in table 2.

Table 2

S.NO	THRUST	WEIGHT
1	8KG	
2	7KG	
3	5KG	
4	30KG	
5	25KG	
6	15KG	

Identity different antennas like patch, helical, and omni-directional

Objectives: At the end of this exercise you shall be able to

- identification of patch, helical, and omni-directional
- record Range of antenna

Requirements	
Tools/Equipments/Instruments	
• Antenna training system	- 1No.

PROCEDURE

Identity the patch, helical, and omni-directional

- 1 Pick one of the antenna, observe the range and record the observations in Table 1.
- 2 Repeat the above step for all the different antenna.

Table 1

S.No	Name of the Antenna	Range
1		
2		
3		
4		
5		
6		
7		
8		

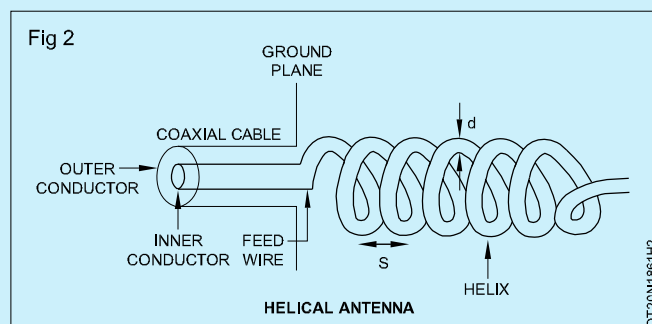
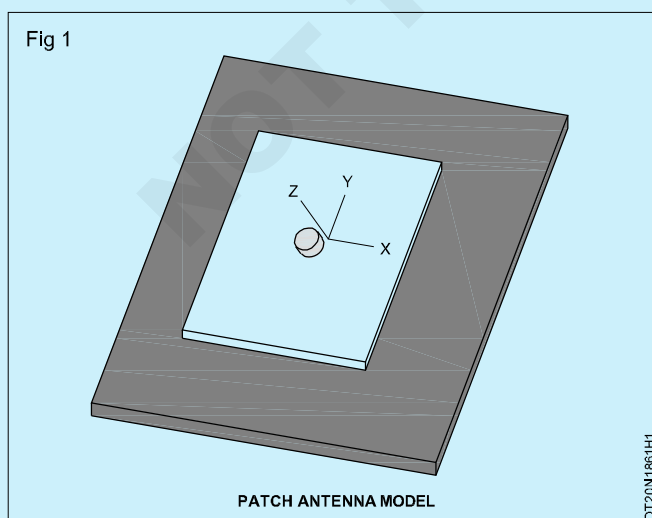

Record and plot radiation pattern of different antennas

Objectives: At the end of this exercise you shall be able to

- record radiation pattern of different antennas
- plot the radiation pattern of different antennas.

Requirements	
Tools/Equipments/Instruments	
• Antenna training system	- 1No.

PROCEDURE

TASK 1 : Record radiation pattern

- | | |
|--|---|
| <ol style="list-style-type: none"> 1 Put the antenna on a Range, this puts the antenna to be measured on a turntable 2 calibrated antenna 100m or so away 3 measure the coupling between them whilst rotating the first antenna and raising up and down the calibrated antenna. | <ol style="list-style-type: none"> 4 Note down the angle and Rx signal in table 1 5 Plot the radiation pattern of antennas in the below graph 6 Repeat the steps for different antenna 7 Get the work checked by the instructor |
|--|---|

S.No	Name of the Antenna	Angle in degree	Rx Signal, db below Max
1		0°	
2		30°	
3		60°	
4		90°	
5		120°	
6		150°	
7		180°	
8		210°	
9		240°	
10		270°	
11		300°	
12		330°	
13		360°	

TASK 2: Plot the radiation pattern of different antennas

- 1 Use the table 1 values
- 2 Plot the pattern in the Fig 1
- 3 Get work corrected by the instructor

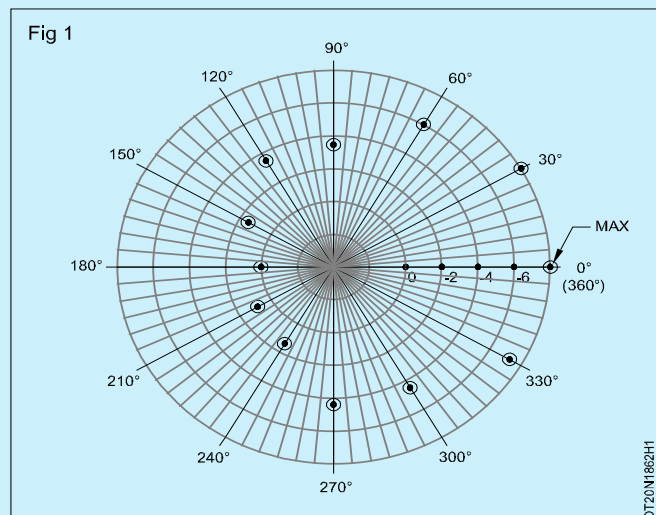

Measure directivity of the antenna

Objective: At the end of this exercise you shall be able to
 • measurement of directivity of the antenna.

Requirements	
Tools/Equipments/Instruments	
• Antenna training system	- 1No.

PROCEDURE

Measure directivity of the antenna

Directivity of an antenna is defined as the ratio of the radiation intensity in a given direction from the antenna to the radiation intensity averaged over all directions. The average radiation intensity is equal to the total power radiated by the antenna divided by 4π .

4 Alternative method:

$$D_0 = \frac{4\pi U_{\max}}{P_{rad}}; P_{rad} = B_0 \left(\frac{\pi}{N} \right) \left(\frac{2\pi}{M} \right) \sum_{j=1}^M \left[\sum_{i=1}^N F(\theta_i, \phi_j) \sin \theta_i \right]$$

5 If there are both θ and ϕ components:

$$D_0 = D_\theta + D_\phi; D_{\{\theta,\phi\}} = \frac{4\pi U_{\{\theta,\phi\}}}{(P_{rad})_\theta + (P_{rad})_\phi}$$

Simple method

- 1 Measure two principal E- and H-plane patterns.
- 2 Determine half-power beamwidths of each pattern.
- 3 Compute directivity using.

4 Measure and fill the table 1

5 Get the work checked by the instructor

$$D_0 = \frac{4\pi(180/\pi)^2}{\Theta_{1d}\Theta_{2d}} \quad (2-27) \quad \text{OR} \quad D_0 = \frac{22.181(180/\pi)^2}{\Theta_{1d}^2 + \Theta_{2d}^2} \quad (2-30b)$$

Table 1

Antenna Type	Typical Directivity	Typical Directivity (dB)
Short Dipole Antenna		
2 Half-Wave Dipole Antenna		
Patch (Microstrip) Antenna		
Horn Antenna		
Dish Antenna		

Drone Technician - Inspect, Test and Execute GPS Navigation and Telemetry Module, Different RF Blocks and Antennas used in RF Transmitter and Receiver

Identify the characteristics of RF circuit blocks like amplifier and filters

Objective: At the end of this exercise you shall be able to

- identification of RF Circuit Blocks

Requirements	
Tools/Equipments/Instruments	
• Antenna training system	- 1No.

PROCEDURE

Characteristics of RF circuit blocks like amplifier and filters

- 1 Check the RF circuit block
- 2 Note down the characteristics
- 3 Get the work checked by the instructor.

Table 1

S.No	RF Components	Characteristics
1	Receivers/Transmitters	
2	Filters	
3	Power Amplifiers	
4	Antenna	
5	Amplifer	

Drone Technician - Inspect, Test and Execute GPS Navigation and Telemetry Module, Different RF Blocks and Antennas used in RF Transmitter and Receiver

Configure and operate 433MHz and 2.4 GHz RC transmitter and receiver

Objectives: At the end of this exercise you shall be able to

- setup transmitter and receiver
- operate transmitter and receiver.

Requirements

Tools/Equipments/Instruments

- | | | | |
|---------------------------------------|--------|--|--------|
| • 433 MHz RF Transmitter and Receiver | - 1No. | • 1M ohm, 47K ohm and 470 ohm Resistor | - 1No. |
| • HT12D Decoder IC | - 1No. | • 7805 Voltage Regulator | - 1No. |
| • HT12E Encoder IC | - 1No. | • 9V Battery (2Nos) | - 1No. |
| • Push Buttons (3 Nos) | - 1No. | • Bread Board (2Nos) | - 1No. |
| • LEDs (3 Nos) | | • Connecting wire | - 1No. |

PROCEDURE

TASK 1 : Wiring the 433MHz RF Transmitter and Receiver Modules to the Arduino

433MHz RF Transmitter and Receiver Module Pinout

PIN Name	PIN Description
VCC	Used to power the RF receiver module.
GND	Ground pin of the module. Connect it with the controllers and encoder/decoders GND pin.
DATA	This is the data pin of the transmitter. It takes the data from the microcontroller or encoder and broadcast it via the antenna.
ANT	The antenna pin is not necessary to use but it is recommended. The module can only operate max 3 meters without an antenna but its range can be extendable up to 100 meters by using a small hookup wire as an Antenna

433 MHz Receiver Module Pinout

PIN Name	PIN Description
VCC	Used to power up the RF receiver module. Unlike the transmitter, the supply voltage of the receiver is 5v.
GND	Ground pin of the module. Connect it with the controllers and encoder/decoders GND pin.
DATA	These pins output the digital data received. The two center pins are internally connected, so we can use either one of them for data output.
ANT	The antenna pin is not necessary to use but is recommended. The module can only operate up to 3 meters without an antenna but its range can be extended up to 100 meters by using a small hookup wire as an Antenna

433MHz RF Transmitter Module Features:

- The Transmitter offers only one-way communication through 433.92MHz frequency at 1Kb data rate
- It operates at a range of 3-12V which is also the power operating volts of most of the microcontrollers and boards.
- The module uses the ASK (Amplitude Shift Key) modulation method to transmits the data.
- It is one of the very low-cost power effective modules for both commercial, hobbyist, and developers.
- 433MHz Transmitter is one of the cheapest RF transmitters and it has a lot of applications and can be used interface with almost every microcontroller.

433MHz RF Receiver Module Features:

- The RF receiver delivers the output to the data pin in an encoded form.
- The operational voltage range of the module is 5V maximum.
- The frequency of the receiver can be changed using a node present on it.
- It is one of the popular and cheapest receivers and has low power consumption.
- 433MHz RF receiver module uses the ASK signal as an input.

Note down the Specifications of 433MHz RF Transmitter Table

- Max range with the antenna in normal Conditions: 100 Meters

Parameters	Values
RX Receiver Frequency	
RX Typical Sensitivity	
RX Supply Current	
RX IF Frequency	
RX Operating Voltage	
TX Frequency Range	
TX Supply Voltage	
TX Output Power	

Note down the Specifications of 433MHz RF Receiver Table

- Max range with the antenna in normal Conditions:

Parameters	Values
RX Receiver Frequency	
RX Typical Sensitivity	
RX Supply Current	
RX IF Frequency	
RX Operating Voltage	

TASK 2: Operate of 433 MHz RF transmitter and receiver Module

Connect transmitter and Receiver module as shown in fig

Get connection checked by the instructor

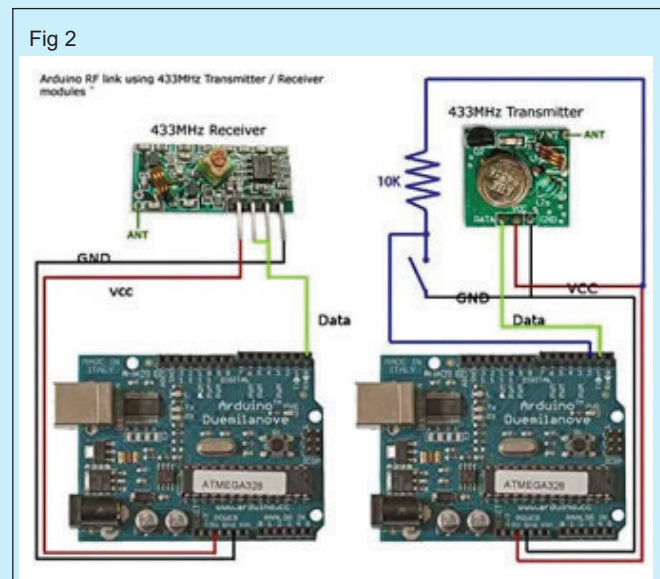

Drone Technician - Inspect, Test and Execute GPS Navigation and Telemetry Module, Different RF Blocks and Antennas used in RF Transmitter and Receiver**Perform and check connectivity of transmitter and receiver used in drone**

Objective: At the end of this exercise you shall be able to

- **practice connectivity between transmitter and receiver.**

Requirements**Tools/Equipments/Instruments**

- Transmitter and receiver - 1No.

PROCEDURE**Connecting the Transmitter and Receiver**

- 1 Collect 2.4 GHz receiver and transmitter
- 2 Connect the blind plug to your BAT slot.
- 3 Connect the power connector of the ESC. Ensure that the ESC is properly connected to the battery and motor.
- 4 Check the receiver's red light flashing continuously.
- 5 Now, turn the transmitter on while holding your blind switch. Make sure that the blind switch has already turned on before activating the transmitter
- 6 Wait for a few minutes. If the red light located on the receiver stops blinking, its successfully established a connection between a receiver and transmitter.

Go through the manual to avoid any issues

Understand GPS and its hardware interfacing with FCB

Objectives: At the end of this exercise you shall be able to

- perform GPS and hardware assembly
- explore GPS.

Requirements	
Tools/Equipments/Instruments	
• GPS	- 1No.
• FCB	- 1No.

PROCEDURE

TASK 1: Understand GPS

- 1 The Global Positioning System (GPS) is a satellite constellation that provides extremely precise positioning, navigation, and timing (PNT) measurements throughout the world. Precision agriculture, driverless vehicles, maritime or aerial surveying, and defense applications have all benefited from GPS, which was one of the first satellite positioning systems.
- 2 The Global Positioning System, or GPS, is a satellite navigation system that offers location, velocity, and time synchronization. GPS may be found almost anywhere. GPS systems can be found in your automobile, smartphone, and watch.

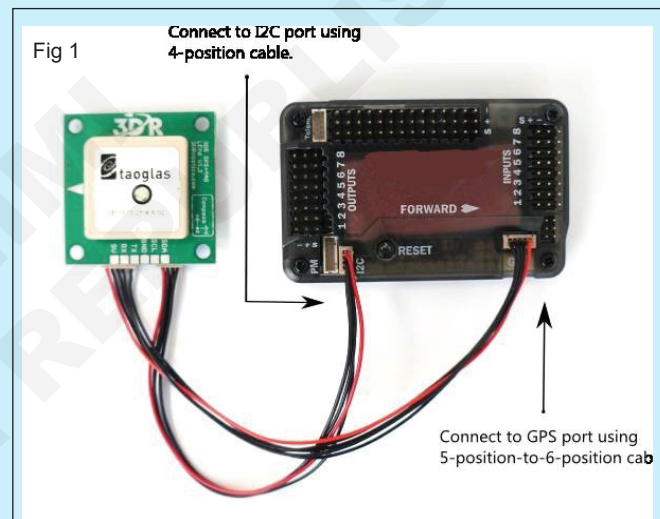

TASK 2: Interface GPS with FCB

- 1 Set the configurations of the FCB which include Oscillator configuration.
- 2 Set the Desired port for LCD including TRIS register.
- 3 Connect the GPS module to the FCB using USART.
- 4 Initialize the system USART in continuous receive mode, with 9600 baud rate and LCD with 4bit mode.
- 5 Take two-character arrays depending on the Length of Latitude and Longitude.
- 6 Receive one character bit at a time and check whether it is started from \$ or not.
- 7 If \$ Receive then it is a string, we need to check GPGGA, these 5 letters and the comma.
- 8 If it is GPGGA, then we will skip the time, and look for the Latitude and Longitude, we will store the Latitude and Longitude in two-character array until N (North) and E (East) not received.
- 9 We will print the array in LCD.
- 10 Clear the array.

Drone Technician - Inspect, Test and Execute GPS Navigation and Telemetry Module, Different RF Blocks and Antennas used in RF Transmitter and Receiver

Connect and Measure and record data of GPS module to determine latitude & longitude

Objectives: At the end of this exercise you shall be able to

- connection of GPS module
- measure and record data of GPS module
- determine latitude & longitude.

Requirements	
Tools/Equipments/Instruments	
• GPS training platform	- 1No.
• FCB	- 1No.

PROCEDURE

Connect and Measure and record data of GPS module to determine latitude & longitude

- | | |
|--|--|
| <ol style="list-style-type: none"> 1 Collect the required components 2 Connect GPS Module with the proper connection and supply power 3 Once GPS activate, it will start tracking the location 4 Data of latitude, longitude, altitude and time of readings obtained from satellites | <ol style="list-style-type: none"> 5 In the laptop/Screen the latitude & longitude data is visible 6 Record the details of the latitude & longitude in Table 1. 7 Repeat the above steps for all other location. 8 Get the recorded information checked by the instructor. |
|--|--|

Table 1

S.No.	Location	Flight Number	HH Latitude	HH longitude	PS Latitude	PS Longitude
1						
2						
3						
4						
5						
6						
7						

Drone Technician - Inspect, Test and Execute GPS Navigation and Telemetry Module, Different RF Blocks and Antennas used in RF Transmitter and Receiver

Perform experiment to record, GPGGA, GPGLL, GPGSA, GPGSV, GPRMC and GPVTG values

Objective: At the end of this exercise you shall be able to

- experiment to record GPGGA, GPGLL, GPGSA, GPGSV, GPRMC and GPVTG values.

Requirements	
Tools/Equipments/Instruments	
• GPS training platform	- 1No.
• FCB	- 1No.

PROCEDURE

TASK 1 : Record GPGGA, GPGLL, GPGSA, GPGSV, GPRMC and GPVTG values

- 1 A GPS receiver module requires only DC power supply for its operation. It will start outputting data as soon as it has identified GPS satellites within its range.
 - 2 GPS module uses plain ASCII protocol known as NMEA developed by National Marine Electronics Association. Hence they are also known as NMEA sentences.
 - 3 Each block of data is referred as “sentence”. Each of these sentences are parsed independently.
 - 4 The default transmission rate of these gps sentences is 4800 bps. Certain GPS modules use serial rate of 9600 bps also. It uses 8 bits for ASCII character, no parity and 1 stop bit.
 - 5 Sentence begins with two letters to represent GPS device. For example, “GP” represent GPS device and so on.
 - 6 Remainder of sentence consists of letters/numerals in plain ASCII. A sentence can not have more than 80 characters.
 - 7 A sentence carry latitude, longitude, altitude and time of readings obtained from satellites.
 - 8 Some sentence data structures are proprietary developed by device manufacturers which begins with letter “P”.
- Following is the generic table which mentions functional description of NMEA output messages.

TASK 2 : GPS sentence | GPGGA

Name or Field	Example	Description
Message ID		
UTC time		
Latitude		
N/S Indicator		
Longitude		
E/W indicator		
Position Fix Indicator		
Satellites used		

HDOP		
MSL Altitude		
Units		
Geoid Separation		
Units		
Age of diff. corr.		
Diff. ref. station ID		
Checksum		
<CR><LF>		

TASK 3 : GPS sentence | GPGLL

Name or Field	Example	Description
Message ID		
Latitude		
N/S indicator		
Longitude		
E/W indicator		
UTC time		
Status		
Mode		
Checksum		
<CR><LF>		

GPS sentence | GPVTG

Name or Field	Example	Description
Message ID		
Course		
Reference		
Course		
Reference		
Speed		
Units		

Speed		
Units		
Mode		
Checksum		
<CR><LF>		

GPS sentence | GPRMC

Name or Field	Example	Description
Message ID		
UTC time		
Status		
Latitude		
N/S indicator		
Longitude		
E/W indicator		
Speed over ground		
Course over ground		
Date		
Magnetic Variation		
Mode		
Checksum		
<CR><LF>		

Drone Technician - Test and Troubleshoot Flight Controller Board (FCB), Electronic Speed Controller (ESC) and its Associated Peripherals

Identify different flight control board and electronic speed control

Objectives : At the end of this exercise you shall be able to

- identification of different flight control board
- identification of different electronic speed control.

Requirements
Material
<ul style="list-style-type: none"> • FCB and ESC training platform - 1 No.

PROCEDURE

TASK 1: Identification of different flight control board

- 1 Pick one of the flight control boards,
- 2 Record the name and other details of identified flight control board in Table 1.
- 3 Repeat the steps for all the remaining flight control boards
- 4 Get the recorded information checked by the instructor.

Table 1

S.No	Name of the flight control boards	Application	Specification

TASK 2: Identification of different electronic speed control

- 1 Pick one of the flight control boards,
- 2 Record the name and other details of identified flight control board in Table 2.
- 3 Repeat the steps for all the remaining flight control boards
- 4 Get the recorded information checked by the instructor.

Table 2

S.No	Name of the electronic speed control	Type of electronic speed control	Specification

Perform programming and configure flight control board (FCB)

Objectives : At the end of this exercise you shall be able to

- perform programming
- configure flight control board.

Requirements

Material

- FCB - 1 No.

PROCEDURE

TASK 1: Entering the program into the FCB

connect your flight controller to the PC and select the com port.

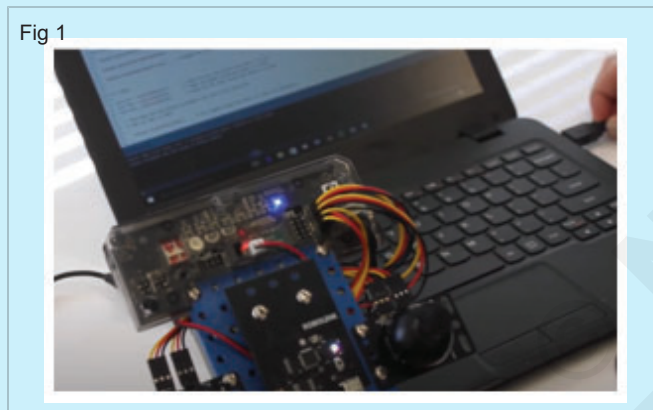

- 1 Refer to the instruction manual and identify all the operating controls and switches.
- 2 Connect the switch to port - 1
- 3 Configure the port - 1 as input port
- 4 Connect the output port to LEDs
- 5 Enter the given program and execute it on the trainer kit.

Before performing any configuration remove all the propellers first.

- 6 Operate the switches one by one and verify the output by using LEDs

Note: The instructor has to explain about the given program and its working. The aboveprogram can be repeated for different Input/Output ports.



TASK 2: Configure Flight Control Board

- | | |
|--|---|
| <ol style="list-style-type: none"> 1 Setting Up Your Receiver - PPM Receiver- SBUS/ IBUS/DSM Receiver 2 Check Your Receiver Is Working 3 Do the sensor calibration properly like accelerometer, compass. 4 Kindly check the throttle failsafe- 5 Failsafe Setup | <ol style="list-style-type: none"> 6 System Configuration 7 Other Features like BlackBox, SDcard etc 8 ESC and Motor Configuration 9 Check motors and orientation 10 Setup Flight Modes 11 Go Fly |
|--|---|

Drone Technician - Test and Troubleshoot Flight Controller Board (FCB), Electronic Speed Controller (ESC) and its Associated Peripherals

Identify, explore and test interconnectivity of different peripheral with FCB

Objectives : At the end of this exercise you shall be able to

- wire up different peripheral
- check different peripheral
- set up different peripheral.

Requirements	
Material	
• FCB	- 1 No.
• Drone Spare Parts	- 1 No.

PROCEDURE

Identify, explore and test interconnectivity of different peripheral with FCB.

- 1 Collect all the relevant components
- 2 Identify all the name of the components and from fig 1.
- 3 Make list of all the peripheral
- 4 Make a connection between all the components with each other's as mention fig 1
- 5 Instructor should check the connect made by the trainee

Fig 1

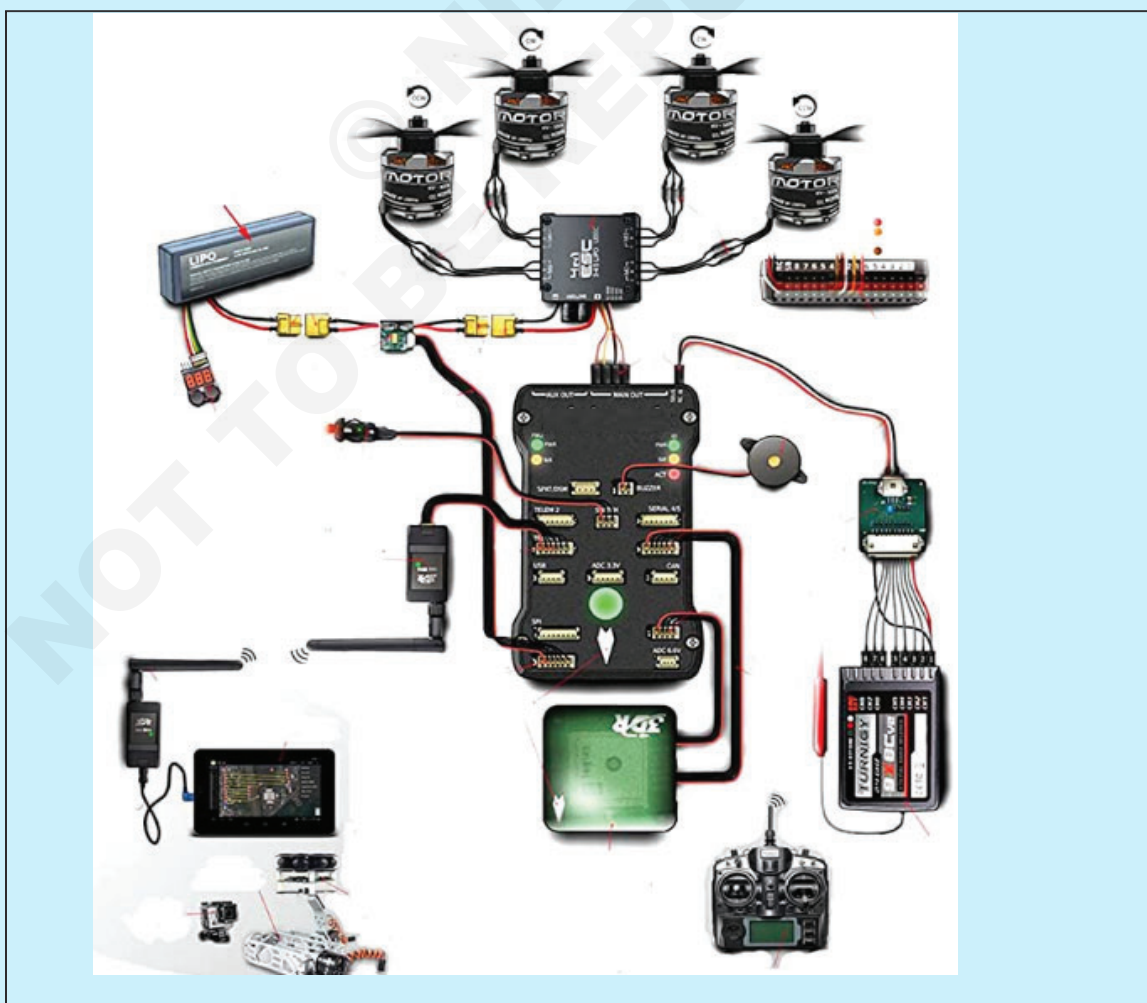

Drone Technician - Test and Troubleshoot Flight Controller Board (FCB), Electronic Speed Controller (ESC) and its Associated Peripherals

Establish connection of FCB with motor, GPS, ESC and sensors

Objectives : At the end of this exercise you shall be able to

- set up connection of FCB
- wire up connection of FCB with motor, GPS, ESC and sensors
- connect FCB with motor, GPS, ESC and sensors.

Requirements	
Material	
Quad copter kit includes - 04 nos	<ul style="list-style-type: none"> • FCB (Flight Controller Board) • Camera • Guard • Lipo Battery and Charger • RF Transmitter and receiver • Drone base • Receiver cables
<ul style="list-style-type: none"> • GPS Module • Propellers • Frame • BLDC Motors • ESC (Electronic Speed controllers) 	

PROCEDURE

Establish connection of FCB with motor, GPS, ESC and sensors .

Instructor should explain about the connection.

- 1 See Fig 1 and make connection as per mention in the figure.
- 2 Get work checked by the Instructor.

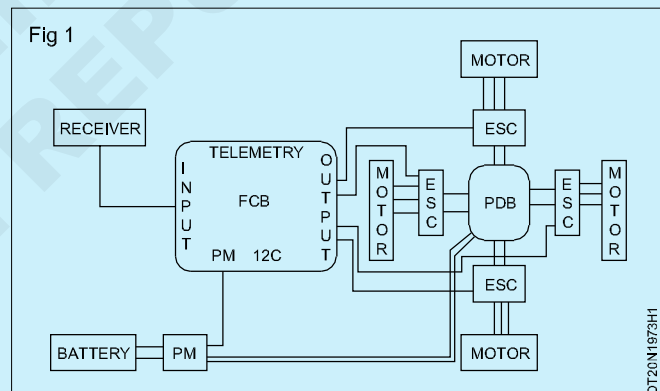

Drone Technician - Test and Troubleshoot Flight Controller Board (FCB), Electronic Speed Controller (ESC) and its Associated Peripherals

Configure, test and record FCB with battery to monitor battery level and perform return to home operation

Objectives : At the end of this exercise you shall be able to

- test FCB with battery to monitor battery level
- monitor battery level
- practice return to home operation

Requirements

Material

- FCB and ESC training platform -1 No .
- Battery -1 No .

PROCEDURE

TASK 1: Configure, test and record FCB with battery to monitor battery level .

- 1 Long press the Set key, power supply to the product, enter the setup interface
- 2 Press the Set key to select the battery specification (Lead-acid battery(P), Lithium battery (L), Fe battery(F))
- 3 Short press the Function key to select the number of battery strings (increasing for the set button, decreasing for function button)
- 4 Long press the Function key to set s mode.

Fig 1



TASK 2: Perform return to home operation.

- 1 Before taking off, set an RTH altitude in the safety section of the app. The RTH altitude should be set within the range provided and it should be higher than any nearby structures.
- 2 When the drone is further than 20 metres from a recorded home point, tap the RTH icon on the left side of the screen and the aircraft will land or return to home automatically.
- 3 Press and hold the RTH icon in the app or the RTH button on the top left of the remote controller. The aircraft will automatically return to home.
- 4 When the drone` is less than 20 metres away from the home point, tap the icon on the left side of the screen and you will see a landing icon. Tap this icon and the drone will land automatically.
- 5 When the drone flight altitude is lower than the preset RTH altitude, the drone will ascend to the RTH altitude and then fly straight back to the home point.
- 6 When the drone flight altitude is higher than the preset RTH altitude, the drone will fly straight back to the home point.
- 7 When it arrives above the home point, it will land automatically and turn off its motors
- 8 When encountering an emergency you can tap the X icon on the left side of the screen or press the Flight Pause and RTH button on the top left of the remote controller to disable the RTH.
- 9 The drone will hover in place after the RTH is disabled allowing you to control the drone manually.

Perform and carry out drone leveling using IMU sensor

Objectives : At the end of this exercise you shall be able to

- practice drone leveling using IMU sensor
- carry out drone leveling using IMU sensor.

Requirements	
Material	
• IMU	-1 No.
• Drone	-1 No.
• Transmitter	-1 No.

PROCEDURE

Proper calibration process

1 Place your drone on a flat/level surface.

Explain about Drone's IMU

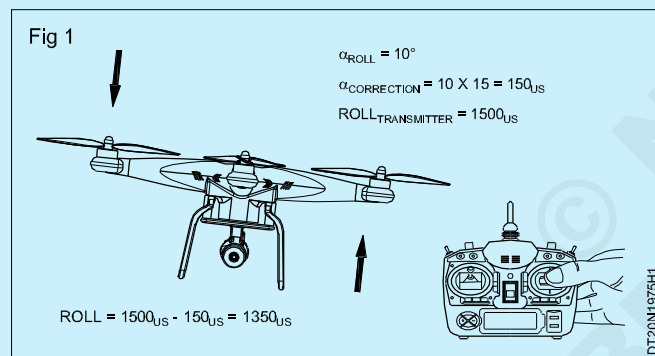

- 2 Put the drone arms folded with its belly.
- 3 Put the drone on its right side.
- 4 Check the lights on the arm of the drone.
- 5 When the green lights are flashing rapidly- it means it is calibrated for that position and it now wants you to move it to the next position.
- 6 Rotate the drone onto its left side.
- 7 Repeat the steps but on the left side.
- 8 Finally face the camera upwards.

Perform calibration of compass, Lidar, and gyro sensor

Objectives : At the end of this exercise you shall be able to

- **Calibrate the compass**
- **Calibrate Lidar**
- **Calibrate gyro sensor.**

Requirements

Material

- Drone with compass - 1 No.
- Lidar - 1 No.
- Gyro sensor - 1 No.

PROCEDURE

TASK 1: Calibrate Compass Calibration.

- | | |
|--|--|
| 1 Start software and connect the drone. | 6 rotate the drone around the specified axis in either/ both directions. |
| 2 Click the Compass sensor button. | |
| 3 Click OK to start the calibration. | 7 Once the calibration is complete a green colour light will blink. |
| 4 Place the drone in flat plate | 8 Software will display Calibration complete |
| 5 Follow the instruction which is coming on screen | |

TASK 2: Calibrate Lidar Calibration.

- | | |
|----------------------|------------------------------------|
| 1 Connect the LiDAR | 3 Collect the photo and LiDAR data |
| 2 Connect the camera | 4 Calibration data acquisition |

TASK 3: Gyroscope Calibration.

- | | |
|--|---|
| 1 Click the Gyroscope sensor button | 6 Once the calibration is complete a green colour light will blink. |
| 2 Place the vehicle on a surface and leave it still. | |
| 3 Click Ok to start the calibration. | 7 Software will display Calibration complete |
| 4 Place the drone in flat plate | |
| 5 Follow the instruction which is coming on screen | |

Fill the Table 1 with your data

Table 1

S.No	Parameters	Before Calibration	After Calibration
1			
2			
3			
4			

Test communication link between FCB and RF transceiver

Objectives : At the end of this exercise you shall be able to

- perform test communication link between FCB and RF transceiver

Requirements

Material

- FCB and RF - 1 No.
- 433 MHz RF Transmitter and Receiver - 1 No.

PROCEDURE

Communication link between FCB and RF transceiver

The radio communication of this controller is based on the transceiver module

- 1 Adding the Flight Controller and the Battery

- 2 Coding the Transmitter

- 3 Coding the Receiver

- 4 Test the RF signal

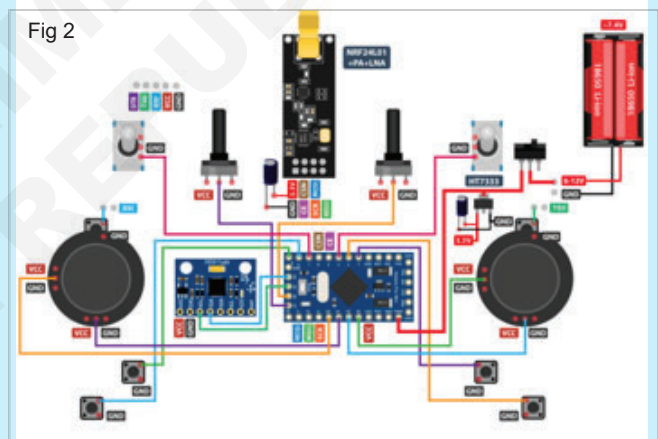
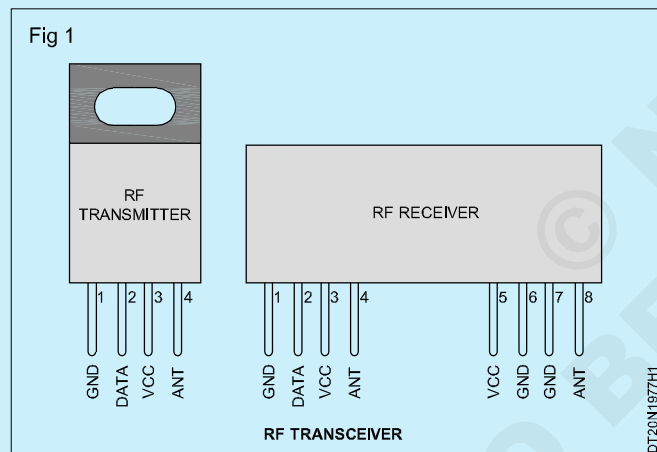

Drone Technician - Test and Troubleshoot Flight Controller Board (FCB), Electronic Speed Controller (ESC) and its Associated Peripherals

Write and upload computer code to FCB to test sensors results

Objective: At the end of this exercise you shall be able to
 • practice of writing code perform code uploading.

Requirements	
Material	
• FCB	-1 No.
• Sensors	-1 No.

PROCEDURE

Write Computer Code upload code to an FCB.

- | | |
|---|--|
| <ol style="list-style-type: none"> 1 Install programming software on your computer/ laptop 2 Connect the FCB to your PC using a USB cable and wait for Windows to begin the USB driver installation process. 3 Go to Device Manager from Start→ Control Panel option and find the COM Ports of your driver. 4 Choose the correct serial COM port for your board. The COM port number will be visible under the Device Manager. 5 Open the source code/sketch, compile it and upload the code to the FCB board by clicking the Upload button. | <ol style="list-style-type: none"> 6 Compile the sensor code and upload it to the FCB board. 7 Test the sensors results and fill in table 1. |
|---|--|

Code

Table 1

S.No	Estimation Position	Actual One
1		
2		
3		
4		
5		
6		
7		

Test and record data of motor connectivity with ESC

Objectives : At the end of this exercise you shall be able to

- carryout motor connectivity with ESC
- wire up motor connectivity with ESC
- record data of motor.

Requirements	
Material	
• Motor	- 4 Nos.
• ESC	- 4 Nos.

PROCEDURE

Test and record data of motor connectivity with ESC

- 1 Collect all the required components and check them for good working condition using multimeter.
- 2 Assemble the arrangement as shown in Fig 1.

Instructor should explain about the wire connections of ESC with motor.

- 3 Get the assembled connection checked by the instructor
- 4 Connect the battery and check their functionality & their connectivity.
- 5 Measure the motor data with no load condition and fill in table 1

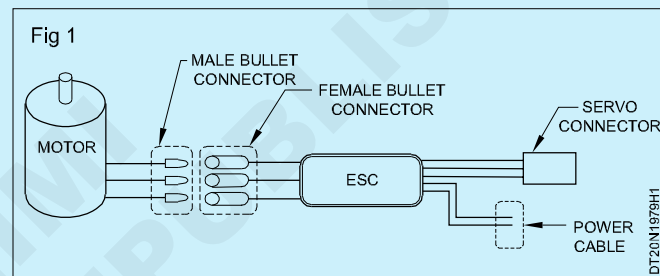

- 6 Put some load on motor and measure motor data and fill in table 1

Table 1

S.No	Voltage	No Load		On Load		Battery	Load Type
		Current	Speed	Current	Speed		
1							
2							
3							
4							
5							
6							

Drone Technician - Test and Troubleshoot Flight Controller Board (FCB), Electronic Speed Controller (ESC) and its Associated Peripherals

Perform motor rotation using FCB and ESC

Objectives : At the end of this exercise you shall be able to

- run motor rotation using FCB and ESC
- practice motor rotation.

Requirements	
Material	
• Motor	- 4 Nos.
• FCB	- 4 Nos.
• ESC	- 4 Nos.
• Battery	- 4 Nos.

PROCEDURE

Perform motor spin directions.

- 1 Turn transmitter on and ensure the flight mode switch is set to Stabilize.

Make sure there are no propellers attach on drone

- 2 Connect battery.
- 3 Arm drone giving armed Command.

Motor Direction is reversed simply by interchanging two of the three ESC to motor power leads.

- 4 When you can Arm successfully, apply a 10% of throttle, and observe and note spin direction of each motor.
- 5 Reverse if any motor spinning in the wrong direction.

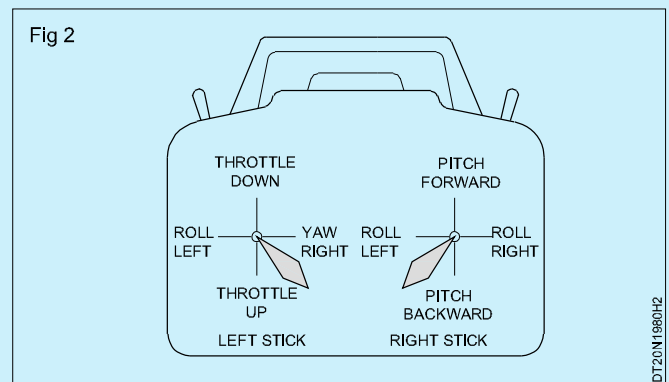
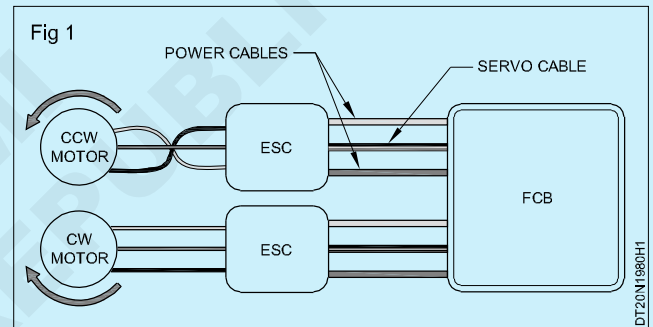

Drone Technician - Test and Troubleshoot Flight Controller Board (FCB), Electronic Speed Controller (ESC) and its Associated Peripherals

Test signal flow into drone to test ESC parameters on FCB to check its operation

Objectives: At the end of this exercise you shall be able to

- understand ESC parameters
- check ESC operation.

Requirements

Material

- Motor - 4 Nos.
- ESC - 4 Nos.

PROCEDURE

Perform ESC parameters on FCB

- 1 Take Esc and FCB
- 2 Make the ESC connection with the FCB
- 3 Open ESC option in the software to check the parameter

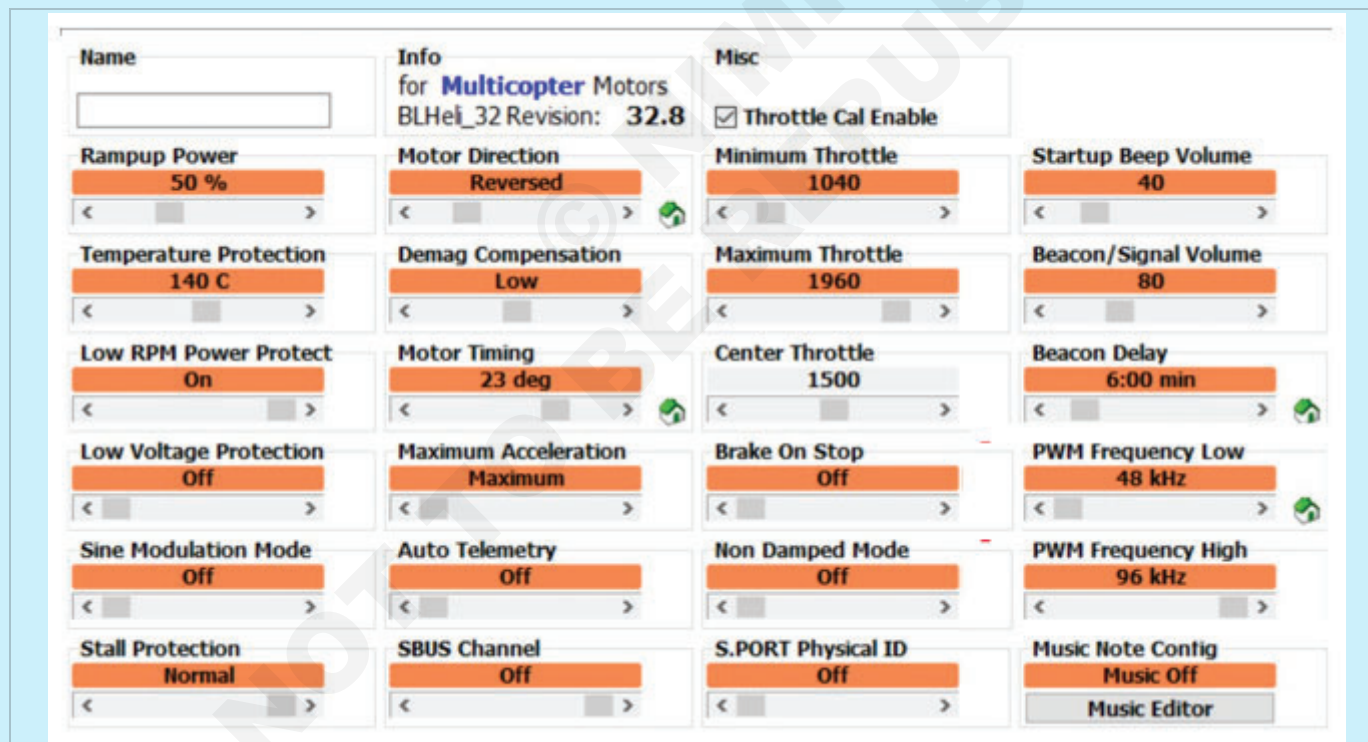

Drone Technician - Test and Troubleshoot Flight Controller Board (FCB), Electronic Speed Controller (ESC) and its Associated Peripherals

Write and upload computer code to FCB to ESC working

Objectives: At the end of this exercise you shall be able to

- use computer code
- upload computer code to FCB
- Check the ESC working.

Requirements

Material

- | | |
|----------|----------|
| • FCB | - 4 Nos. |
| • ESC | - 4 Nos. |
| • Laptop | - 1 No. |

PROCEDURE

Write and upload computer code to FCB to ESC working.

- 1 Install programming software on your computer/ laptop
- 2 Connect the FCB to your PC using a USB cable and wait for Windows to begin the USB driver installation process.
- 3 Go to Device Manager from Start→ Control Panel option and find the COM Ports of your driver.
- 4 Choose the correct serial COM port for your board. The COM port number will be visible under the Device Manager.
- 5 Open the source code/sketch, compile it and upload the code to the FCB board by clicking the Upload button.
- 6 Compile the ESC code and upload it to the FCB board.
- 7 Test the ESC results and fill in table 1.

Code

Drone Technician - Calibrate and Troubleshoot Drone Gimbal and Drone Payload

Identify the different types of drones and its application in different areas

Objectives : At the end of this exercise you shall be able to

- identification of different types of drones
- determine drones and its application in different areas.

PROCEDURE

Determine Different types of Drones.

- 1 Identify the different types of drones from fig 1 and write their names and application with the help of the diagram in Table 1.
- 2 Get it checked by the instructor.



Table 1

S. No	Type of Drone	Application
1		
2		
3		
4		

Drone Technician - Calibrate and Troubleshoot Drone Gimbal and Drone Payload

Identify different features and controls of HD and thermal image camera

Objectives : At the end of this exercise you shall be able to

- check different features and
- check the controls of HD and thermal image camera.

Requirements	
Material	
• HD Payload	- 02 nos.

PROCEDURE

TASK 1: Identify different features and controls of HD

- | | |
|---|---|
| 1 Identify the different features and controls of HD | 3 Get the work checked by the instructor. |
| 2 check the HD camera and analysis its feature and note down in Table 1 | |

Instructor Explain about the controls of HD

Table 1

Pan and tilt control	
Automatic panning	
Zoom control	
Iris control	
Shutter control	

TASK 2: Thermal Image Camera

- | | |
|--|--|
| 1 Identify the different features and controls of and thermal image camera | 3 Get the work checked by the instructor |
| 2 Analysis its features and note down in Table 2 | |

Table 2

Features	
Resolution	
Focus	
Temperature range	
Lens options	
Saving images and additional data	
Color palettes	
Color alarms	
Emissivity and reflected temperatures	
Spot markers	
Battery type and life	

Test and install Gimbal camera assembly

Objectives : At the end of this exercise you shall be able to

- assemble camera Gimble
- test camera Gimble.

Requirements**Material**

- Drone Gimbal Set with motor and control - 1 No.

PROCEDURE**TASK 1: Test assembly of camera Gimble**

- 1 The all the essential parts to assemble gimble Parts
- 2 Build the Camera Cage
- 3 Assemble the Outside Frame
- 4 Install Pitch Motor and Bearings
- 5 Install Yaw Motor
- 6 Build Mounting Arm
- 7 Solder the Motor Wires
- 8 Connect Everything for Testing
- 9 Mounting the Gimble
- 10 Test whether it's working fine or not

Fig 1

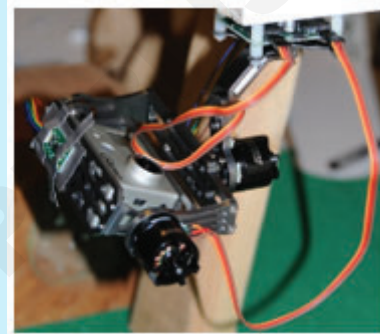

Perform and test Gimbal stabilization

Objectives : At the end of this exercise you shall be able to

- practice Gimbal stabilization
- test Gimbal stabilization.

Requirements

Material

- Drone Gimbal Set with motor and control - 01 nos.

PROCEDURE

TASK 1: Perform Gimbal Stabilization

- 1 Take the Gimble. 3 Observe the values shown by tilt and roll of the gimbal.
- 2 The tilt and roll the gimbal with the target position and angle.

Plot the graph for Gimbal control response according to the change of up and down position

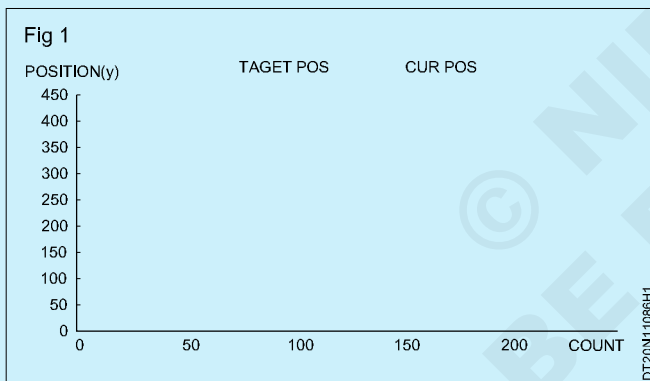

Plot the graph for Gimbal control response according to left and right angle change

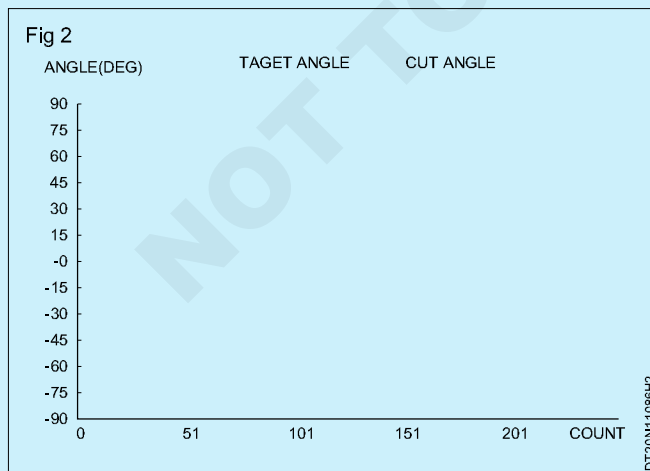

Perform drone camera control using x, y, and z axes rotation

Objectives : At the end of this exercise you shall be able to

- setup camera control

Requirements**Material**

- camera - 1 No.

PROCEDURE

TASK 1: Practice camera control using x, y, and z axes rotation

- 1 Move the transmitter joystick forward to ascend, backward to descend, and left or right to rotate.
- 2 With the transmitter right joystick, accelerate forward, backward, and side-to-side.
- 3 Check by taking photos and record video.

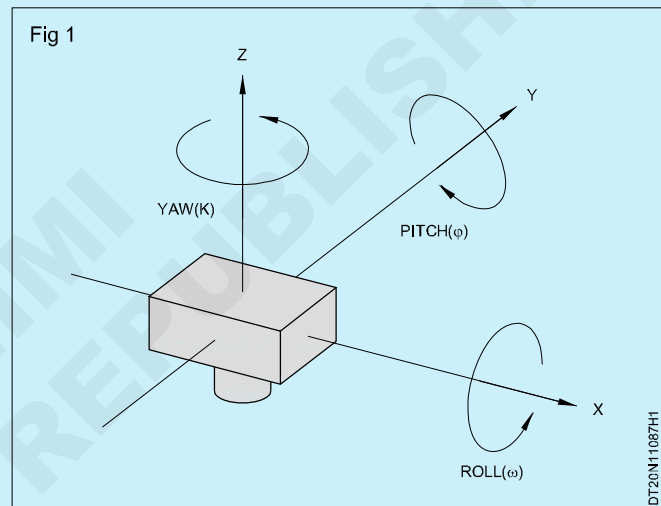

Drone Technician - Calibrate and Troubleshoot Drone Gimbal and Drone Payload**Test and install different cameras on gimbal assembly.**

Objectives : At the end of this exercise you shall be able to

- fix the different cameras on gimbal

Requirements**Material**

- Drone Gimbal - 01 No.
- Cameras - 01 No.

PROCEDURE**TASK 1: Perform gimbal assembly**

- 1 Collect different cameras for attaching in gimbal as showing in Fig 1.
- 2 Pick one camera and fix in the gimbal.
- 3 Check whether camera is properly fix or not.
- 4 Test whether it's working fine or not.
- 5 Repeat the same with different camera.

Fig 1



Drone Technician - Calibrate and Troubleshoot Drone Gimbal and Drone Payload**Practice remote sensing, surveying & mapping, photogrammetry and precision agriculture using HD and thermal image camera**

Objectives : At the end of this exercise you shall be able to

- handle HD camera
- handle thermal image camera.

Requirements**Material**

- | | |
|--------------------------|----------|
| • Thermal Camera Payload | - 2 Nos. |
| • HD Payload | - 2 Nos. |
| • Drone | - 1 No. |

PROCEDURE**Practice of using HD and Thermal image camera**

- 1 Trainer takes the trainee to the field with drone.
- 2 And arrange all the equipment to do practice for remote sensing, surveying & mapping, photogrammetry and precision agriculture.
- 3 Fly drone as per instruction.
- 4 Understand all the parameter involve in the HD and thermal image camera.

Drone Technician - Calibrate and Troubleshoot Drone Gimbal and Drone Payload

Identify and record different application drones and their logged data for investigation

Objectives : At the end of this exercise you shall be able to

- identify different application drones
- analysis logged data for investigation.

Requirements	
Material	
• Drone	-1 No.

PROCEDURE

Identification and record different application drones and their logged data for investigation.

1 Downloading Logs from the Flight Controller

Step 3: On the bottom left, select the “DataFlash Logs” tab and push the “Download DataFlash Log Via Mavlink” button.

Step 1: Connect your vehicle to the ground station using the micro USB cable.

Step 2: Open the Mission Planner’s Flight Data screen.

2 Analyzing the Logs

S.No.	Type of Drone Application	Logged data for investigation
1		
2		
3		
4		
5		
6		
7		

Drone Technician - Identify and Resolve Common Error Messages and Corrections by Software Debugging

Identify bugs in the software program as per the algorithms used and the libraries

Objective: At the end of this exercise you shall be able to

- **check bugs in software.**
-

Requirements	
Material	
• Laptop latest configuration	-1 No.

PROCEDURE**Find software bugs**

- | | |
|---------------------------|------------------------|
| 1 Identify the Error | 4 Prove the Analysis |
| 2 Find the Error Location | 5 Cover Lateral Damage |
| 3 Analyze the Error | 6 Fix & Validate |

Drone Technician - Identify and Resolve Common Error Messages and Corrections by Software Debugging

Resolve common error messages and apply the correct logic

Objective: At the end of this exercise you shall be able to

- carryout the error message.

PROCEDURE

Carryout the error message

- 1 Begin testing additional related scenarios
- 2 Note the current state of the error
- 3 Check to see if it has already been reported
- 4 Report It As Soon As Possible

Common Error	Correct Logic
Logical error	
Usability error	
Functionality error	
Security error	
Performance error	
Calculation error	
Syntax Error	
Control Flow error	
System-level integration bugs	
Unit level bugs	

Drone Technician - Identify and Resolve Common Error Messages and Corrections by Software Debugging

Perform firmware configuration and updates

Objective: At the end of this exercise you shall be able to

- **practice firmware configuration and updates.**

PROCEDURE**Practice firmware configuration and updates**

Ensure the drone's battery level is above 50% before updating the firmware.

- 1 Download the app.
- 2 Connect your mobile device to the available network.
- 3 Launch the latest version of the Tello mobile app.
- 4 Download the latest firmware version. The app will notify if there is an update.
- 5 Select Start to download the firmware.
- 6 Connect your device to the drone's Wi-Fi once the download of the firmware is complete.
- 7 Click Update to update the firmware on the app.
- 8 After the update is complete, the app will prompt that the update was successful and the drone will automatically restart.

Make sure all propellers are removed before configuring drone

Drone Technician - Identify and Resolve Common Error Messages and Corrections by Software Debugging

Download and Install App / Menu / Planning / Set-up / Flight / Application

Objectives: At the end of this exercise you shall be able to

- perform app installation
 - perform app setup
 - select application.
-

Requirements	
Material	
• Laptop latest configuration	- 1 No.

PROCEDURE**Set up the flight app**

- 1 Download the App from the App Store
- 2 Connect To the Drone's Wifi Network
- 3 Simple mission planning
- 4 Select your drone
- 5 Select a mission
- 6 Adjust your drone flight plan and parameters
- 7 Start and fly
- 8 Check the results

Drone Technician - Identify and Resolve Common Error Messages and Corrections by Software Debugging

Demonstration and perform base station software to debugging to get GPS and flight data

Objectives: At the end of this exercise you shall be able to

- understand flight data
- perform base station software.

Requirements	
Material	
• Laptop latest configuration	- 1 No.
• GPS	- 1 No.

PROCEDURE

Demonstrate the Base Station Software

Step 1: Open Mission Planner Open the software

Step 2: Select desired COM

Step 3: Press Connect

Now you can see it's connected

Go to Flight Data and Armed your drone

Click on the flight data, on screen it show flight data as shown in Fig 2.

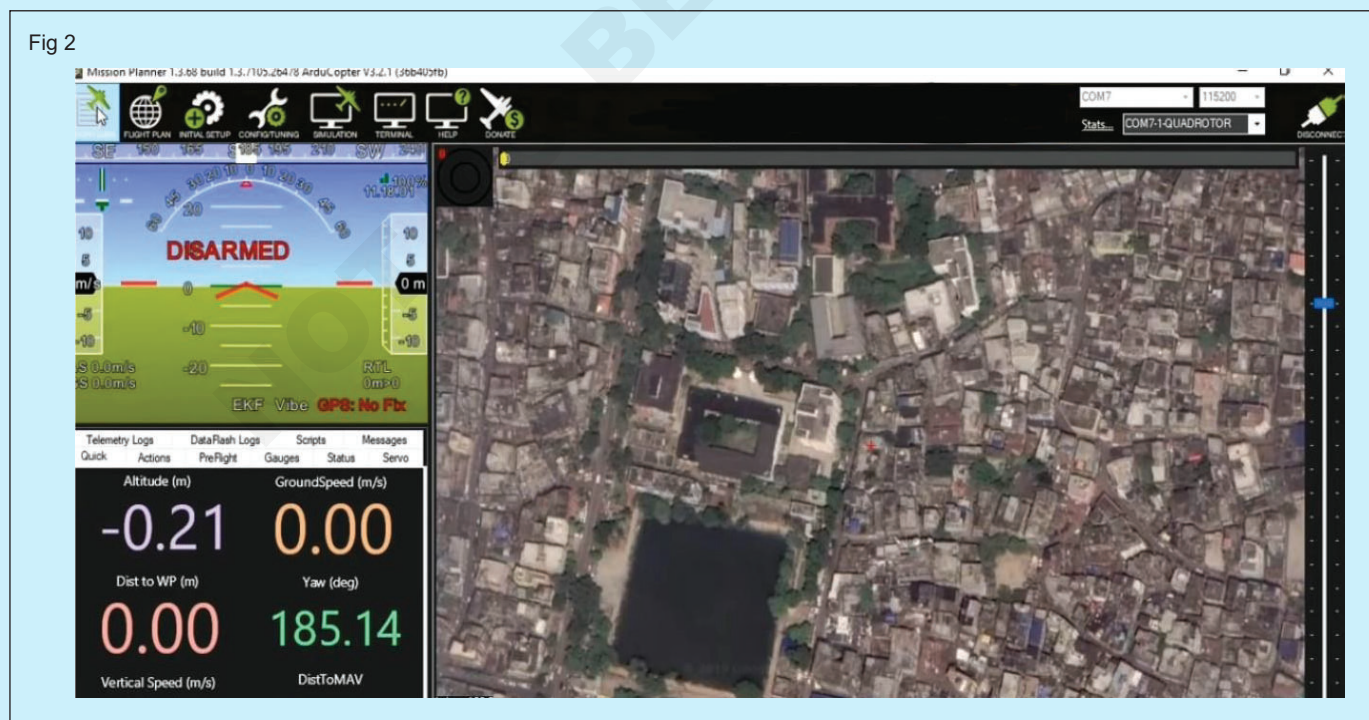
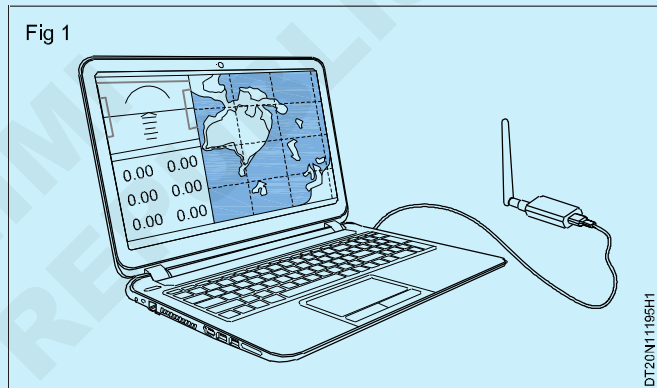

Flight Data Screen shows

Instruction explain the following flight data to the Trainee

- 1 Airspeed (Groundspeed if no airspeed sensor is fitted)
- 2 Crosstrack error and turn rate (T)
- 3 Heading direction
- 4 Bank angle
- 5 Telemetry connection link quality (averaged percentage of good packets)
- 6 GPS time
- 7 Altitude (Blue bar is the rate of climb)
- 8 Airspeed
- 9 Groundspeed
- 10 Battery status
- 11 Artificial Horizon
- 12 Aircraft Attitude
- 13 GPS Status
- 14 Distance to Waypoint > Current Waypoint Number
- 15 Current Flight Mode

© NIMI
NOT TO BE REPUBLISHED

Drone Technician - Identify and Resolve Common Error Messages and Corrections by Software Debugging

Perform experiments on software debug tool use to identify coding errors at different stages

Objectives: At the end of this exercise you shall be able to

- practice software debugging tool
- identification of coding error.

PROCEDURE

Practice to identify coding errors

- 1 Check the execution of the program
- 2 Go to **Menu**→**Debug**→**Set/Modify Conditional Breakpoint**
- 3 Using the keyboard, press Function key to run the code.

Fig 1

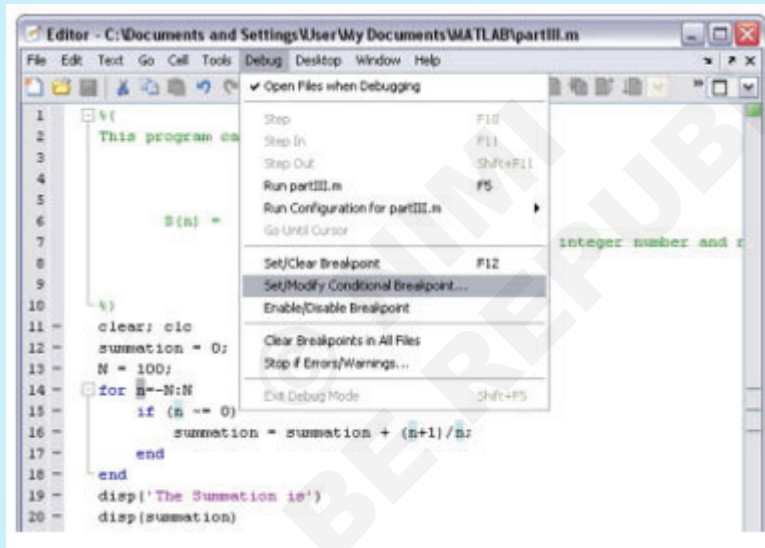

Drone Technician - Identify and Resolve Common Error Messages and Corrections by Software Debugging

Setup python and Arduino environment

Objectives: At the end of this exercise you shall be able to

- setup python
- create Arduino environment.

PROCEDURE

TASK 1: Setup python

- 1 First, download all the required software and packages
- 2 Download Python by going to the official site. Click [here](#) to download.
- 3 Once Python is downloaded open the Python installer to complete the Python installation process.
- 4 It is time to install pip package manager. Open command prompt.
- 5 Download pip using pip command.

Fig 1



TASK 2: Arduino Software

- 1 Connect the board to your PC.
- 2 Open Arduino IDE. A new window will open, with a blank sketch
- 3 Setup Arduino board ports, go to:
Tools>Boards>Arduino AVR Boards>Arduino Uno
- 4 For port selection go to:
Tools>Port>Serial ports>COM:
- 5 Configure the board settings.
- 6 Write the code.
- 7 Press a button on the IDE to upload the program to the board.

Remote automatic drone operation using Python

Objective: At the end of this exercise you shall be able to

- operate automatic drone using Python.

PROCEDURE**Setup Automatic Drone Operation****Download All the Required Software and Packages**

First, download all the required software and packages:

- 1 Open Pythen Software
- 2 Download dronekit python by using pip install dronekit = 2.9.2
- 3 Write the python script for drone operation
- 4 Execute the program
- 5 Fly drone safely sand check the code.

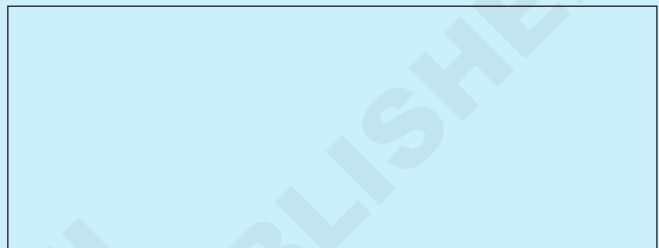
Code

© NIMI
NOT TO BE REPUBLISHED

Drone Technician - Identify and Resolve Common Error Messages and Corrections by Software Debugging

Knowledge and advantage of preventative maintenance of drone

Objective: At the end of this exercise you shall be able to
 • create preventative maintenance of drone.

Requirements	
Material	
• Drone	- 1 No.

PROCEDURE

TASK 1: Knowledge of preventative maintenance of drone

Preventive maintenance refers to any routine inspections, cleanings, part replacements, and machine maintenance performed at regularly scheduled intervals to reduce the likelihood of equipment failure, including repairs.

TASK 2: Benefits of preventive maintenance

- | | |
|------------------------------|---|
| 1 Extends asset life | 6 Maximizes Equipment Lifespan |
| 2 Reduces maintenance | 7 Helps Keep Workers Safe |
| 3 Boosts productivity | 8 Helps Ensure Regulatory Compliance |
| 4 Reduces unplanned downtime | 9 Maintain the performance of drone. Increase efficiency, ensure safety and complete maintenance records. |
| 5 Minimizes Downtime | |

PREVENTIVE MAINTENANCE CHECKLIST

S.No	Task to be perform	Inspected Okay	Repaired and adjusted	Comment
1				
2				
3				
4				
5				
6				

Drone Technician - Identify and Resolve Common Error Messages and Corrections by Software Debugging

Upgrade/downgrade drone firmware Identify error message and resolve approach

Objectives: At the end of this exercise you shall be able to

- **upgrade/downgrade drone firmware**
 - **identify error message and resolve approach.**
-

PROCEDURE

Upgrade/downgrade drone firmware Identify error message and resolve approach

1 Check current firmware version

4 Upgrade to most current version

2 downgrade to previous firmware version

5 Check if issue is still present

3 Check if issue is still present

© NIMI
NOT TO BE REPUBLISHED

Drone Technician - Inspect, Test and Execute Primary and Secondary Servicing with Troubleshoot Malfunctioning, and Repair Issues Discovered

Perform primary and secondary servicing based upon the checklist

Objective: At the end of this exercise you shall be able to

- Practice primary and secondary servicing.
-

PROCEDURE**Practice primary and secondary servicing**

The primary and secondary function of maintenance includes

- 1 Equipment inspection, cleaning and lubrication.
- 2 Alterations to existing equipment's and parts.
- 3 Maintenance of existing connections, parts, and joints.

© NIMI
NOT TO BE REPUBLISHED

Drone Technician - Inspect, Test and Execute Primary and Secondary Servicing with Troubleshoot Malfunctioning, and Repair Issues Discovered

Test and diagnose drone after 100 hours of flying for preventive maintenance

Objectives: At the end of this exercise you shall be able to

- Test drone
- diagnose drone.

Requirements	
Material	
• Drone	- 1 No.

PROCEDURE

Test and diagnose drone after 100 hours

- 1 After completing 100 hours of flight.
- 2 Traniee take drone and perform inspection.
- 3 Do visual inspection of complete drone
- 4 Check working condition of each components properly.
- 5 Test and find any defects in the drone parts.
- 6 Fill the table 1 get corrected by the instructor.

Table 1

Parts	Condition	Action
Propellers		
Motors		
Gimbal		
Indicator lights		
Screws		
GPS		
Landing gear		
Batteries		
Electronic Speed Controller		
Compass		
Wiring		
Camera		

Drone Technician - Inspect, Test and Execute Primary and Secondary Servicing with Troubleshoot Malfunctioning, and Repair Issues Discovered

Test and diagnose drone after 500 hours of flying

Objectives: At the end of this exercise you shall be able to

- test drone
- diagnose drone.

Requirements	
Material	
• Drone	-1 No.

PROCEDURE

Test and diagnose drone after 500 hours

- 1 After completing 500 hours of flight.
- 2 Traniee take drone and perform inspection.
- 3 Do visual inspection of complete drone
- 4 Check working condition of each components properly.
- 5 Test and find any defects in the drone parts.
- 6 Fill the table 1 get corrected by the instructor.

Table 1

Parts	Condition	Action
Propellers		
Motors		
Gimbal		
Indicator lights		
Screws		
GPS		
Landing gear		
Batteries		
Electronic Speed Controller		
Compass		
Wiring		
Camera		

Drone Technician - Inspect, Test and Execute Primary and Secondary Servicing with Troubleshoot Malfunctioning, and Repair Issues Discovered

Knowledge about drone troubleshooting check list like Equipment check, System reset, calibration, Motor Troubleshooting, Gimbal rotation, Battery Maintenance, and RF Signal and hardware

Objective: At the end of this exercise you shall be able to

- **perform troubleshooting.**
-

PROCEDURE**Knowledge about drone troubleshooting****Equipment check**

Inspect all component for visual damage. If the part is damaged, it will cause the drone to behave incorrectly.

Replace or repair damaged components.

System reset

Step 1: Hold down the power button on the drone for few seconds until you hear three beeps. Then do the same on the controller.

Step 2: The next thing is to power off both the controller and the drone.

Calibration

Follow the calibration procedure for your flight controller to ensure your compass and IMU are properly calibrated before flight.

Motor Troubleshooting

drone motor may not be spinning due to visible obstructions, a bent motor shaft, worn out mounts, or other broken components inside the motor housing.

Gimbal rotation

By inspecting your take-off site, you can check if the gimbal motor overload is caused by obstructions stopping the gimbal from rotating.

Battery Maintenance

Battery cell voltage difference is less than 0.1V after the battery is fully charged and left stationary for 6 hours. This can be checked in the drone's flight app. Battery should not swollen, leaky, or damaged.

RF Signal

The basic setup to intercept drone transmission consists of an antenna, RF receiver, and a processing unit. Recorded data are usually post-processed and further analyzed in software, using either a frequency-domain or time-domain approach.

Hardware

Inspect all hardware components. If the part is damaged, it will cause the drone to behave incorrectly.

Replace or repair damaged Hardware

Drone Technician - Inspect, Test and Execute Primary and Secondary Servicing with Troubleshoot Malfunctioning, and Repair Issues Discovered

Diagnose the common drone problem like GPS signals are blocked, Decreased battery life, Wrong direction during flight, Flight Planning, Mechanical issue, and Firmware issue

Objective: At the end of this exercise you shall be able to

- **diagnose the common drone problem.**

PROCEDURE

Diagnose the common drone problem

- 1 Perform visual inspection of complete drone
- 2 Some common drone problems are to diagnose

Common Drone Problem	Reason
GPS signals are blocked,	
Decreased battery life,	
Wrong direction during flight	
Flight Planning,	
Mechanical issue	
Firmware issue	

Drone Technician - Inspect, Test and Execute Primary and Secondary Servicing with Troubleshoot Malfunctioning, and Repair Issues Discovered

Inspect drone before and after each flight

Objective: At the end of this exercise you shall be able to

- inspect drone.

PROCEDURE

Drone before and after each flight

- 1 Inspect every component carefully for visual damage and check before and after each flight
- 2 After the whole unit has been inspected, make a note if anything needs to be replaced or repaired.
- 3 Write the condition of drone in table 1

Table 1

Parts	Before	After
Propellers		
Motors		
Gimbal		
Indicator lights		
Screws		
GPS		
Landing gear		
Batteries		
Electronic Speed Controller		
Compass		
Wiring		
Camera		

First time drone hardware assembly and test

Objectives: At the end of this exercise you shall be able to

- assemble drone hardware
- test drone hardware.

Requirements

Material

Quad copter kit includes

- 4 Nos.

- GPS Module
- Propellers
- Frame
- BLDC Motors
- ESC (Electronic Speed controllers)
- FCB (Flight Controller Board)
- Camera
- Guard
- Lipo Battery and Charger
- RF Transmitter and receiver
- Drone base
- Receiver cables
- Hovering function using LiDAR sensor
- Mission planning function: Waypoint routing, event execution .

PROCEDURE

TASK 1: Perform assembling of drones.

A completed Assembled quadcopter (4 motor) drone shown in Fig 1.

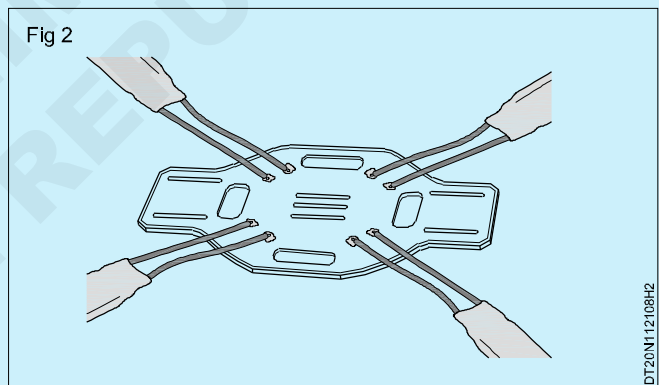
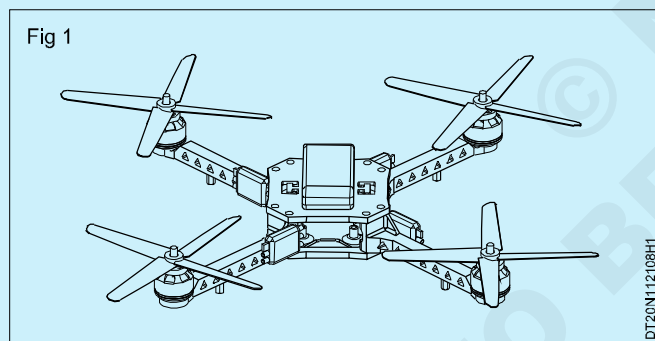

3 Take the connector XT60 and silicon wire make Battery wire. (Fig 3).



- 4 Soldering the battery wire to the Bottom plate.
- 5 Take the Power Module and do soldering it to the Bottom plate.
- 6 Take the motors attach them at the end of arms, Screws tightly with Allen key (Fig 4).

Use tags and fix the ESCs and Receiver to the arm.

Use tags and double tape to fix the flight controller and the Receiver to the bottom plate with Familiarize with the parts and remote controls.

- 1 First take the bottom plate and do the Pre soldering to it.
- 2 Next take the four ESC's and do soldering the 4 ESCs to the Bottom plate.(Fig 2).

Now check the all connections by using multimeter for any shortage connections.

Use hot glue to the soldering wires to prevent from short circuit.

Fig 4



7 Attach the Four Arms to the Bottom plate and tight them with screws.(Fig 5).

Fig 5

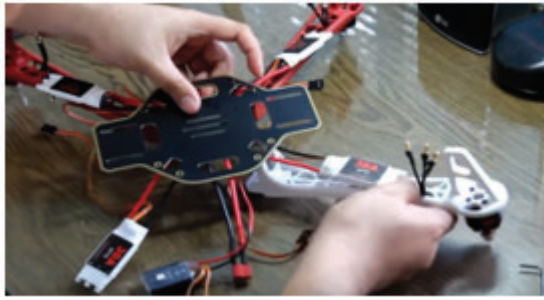

8 Take the ESC's wires and connect them to the motor.
9 Take the flight controller and connect the four ESC servo wires to the flight controller.(Fig 6).

Fig 6

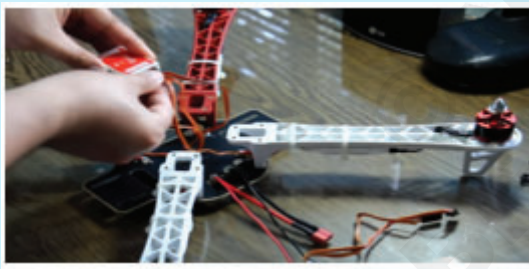

10 Connect the Power Module and Receiver to the flight controller by using servo wire cables.(Fig 7).

Fig 7



11 Connect the GPS module to the flight controller (Fig 8).
12 Finally cross check all the connections and Show to your instructor.

Fig 8

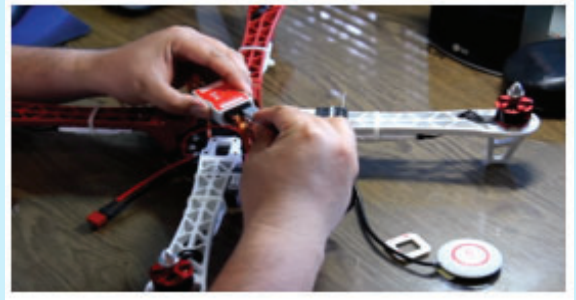

13 Fix the top plate (Fig 9).

Fig 9



14 Attach the four landing gears at the bottom plate
15 Set up the GPS mount to the top plate using double sided tape (Fig 10)

Fig 10



16 Connect the battery. (Fig 11)

Fig 11



17 In the end attach Clock-wise propellers with Clock-wise motors and counterclockwise propellers with counterclockwise motors (Fig 12)

18 Go to field with the trainee and test drone



© NIMI
NOT TO BE REPUBLISHED

Drone Technician - Inspect, Test and Execute Primary and Secondary Servicing with Troubleshoot Malfunctioning, and Repair Issues Discovered**Test, locate the fault and repair a wiring of drone**

Objectives : At the end of this exercise you shall be able to

- locate the fault
- test the fault
- perform repair a wiring of drone.

PROCEDURE**Test, locate the fault and repair a wiring of drone**

Perform fault diagnosis on electrical wiring harness.

Inspect for faults

- 1 Check each connection point

Power down the system

Fig 1

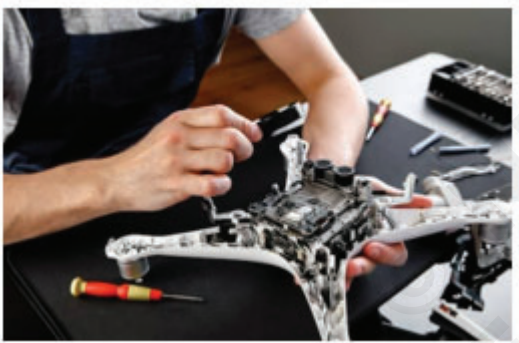

- 2 Locate loose connections

Checking all wiring

Fig 2



- 3 Refer to manual for loose connections
- 4 Strip the ends of loose wires
- 5 Solder loose wires

Stripping and soldering the old segment or replacing a segment altogether.

- 6 Replace unsuitable wire

Drone Technician - Inspect, Test and Execute Primary and Secondary Servicing with Troubleshoot Malfunctioning, and Repair Issues Discovered

Check bent or cracked on legs and feet of the drone

Objectives: At the end of this exercise you shall be able to

- check bent
 - identify cracked on legs and feet of the drone.
-

PROCEDURE**Inspect drone legs for cracks**

- 1 Make sure the legs and feet of the unit are not bent or cracked, and that all rubber shock absorbers are intact.
- 2 Without this module, the drone would not be able to perform a safe landing.
- 3 If any parts are damaged or missing they will need to be ordered from your manufacturer and re-fitted.
- 4 Comments on landing gear damage

© NIMI
NOT TO BE REPUBLISHED

Drone Technician - Inspect, Test and Execute Primary and Secondary Servicing with Troubleshoot Malfunctioning, and Repair Issues Discovered

Demonstration drone wiring connections with different parts

Objective: At the end of this exercise you shall be able to

- visualize the drone wiring connections with different parts.

Requirements

Material

- | | | |
|--------------------------------------|----------|---------------------------------|
| Quad copter kit includes | - 4 Nos. | • FCB (Flight Controller Board) |
| • GPS Module | | • Camera |
| • Propellers | | • Guard |
| • Frame | | • Lipo Battery and Charger |
| • BLDC Motors | | • RF Transmitter and receiver |
| • ESC (Electronic Speed controllers) | | • Drone base |
| | | • Receiver cables |

PROCEDURE

Visualize the drone wiring

Fig 1

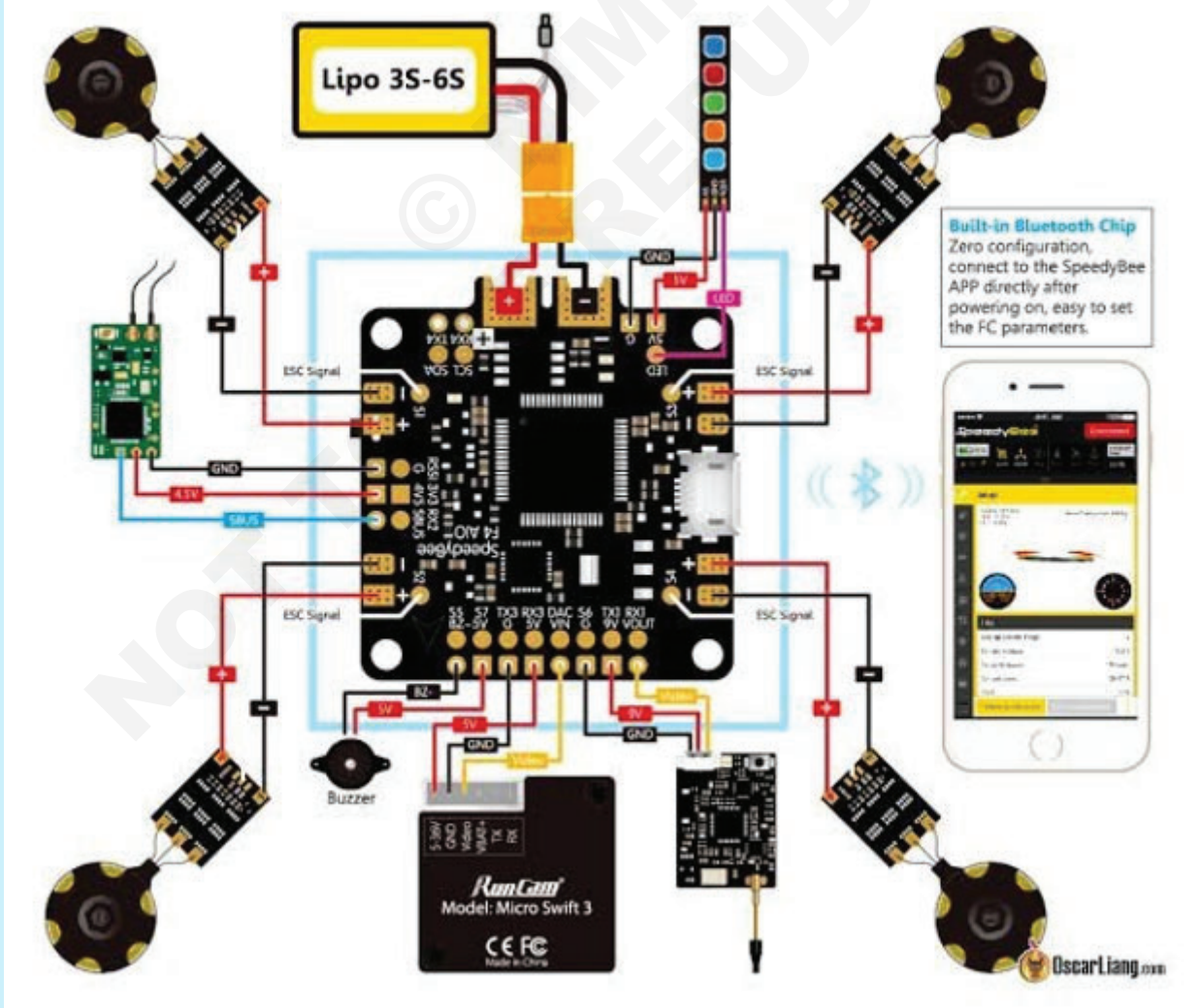
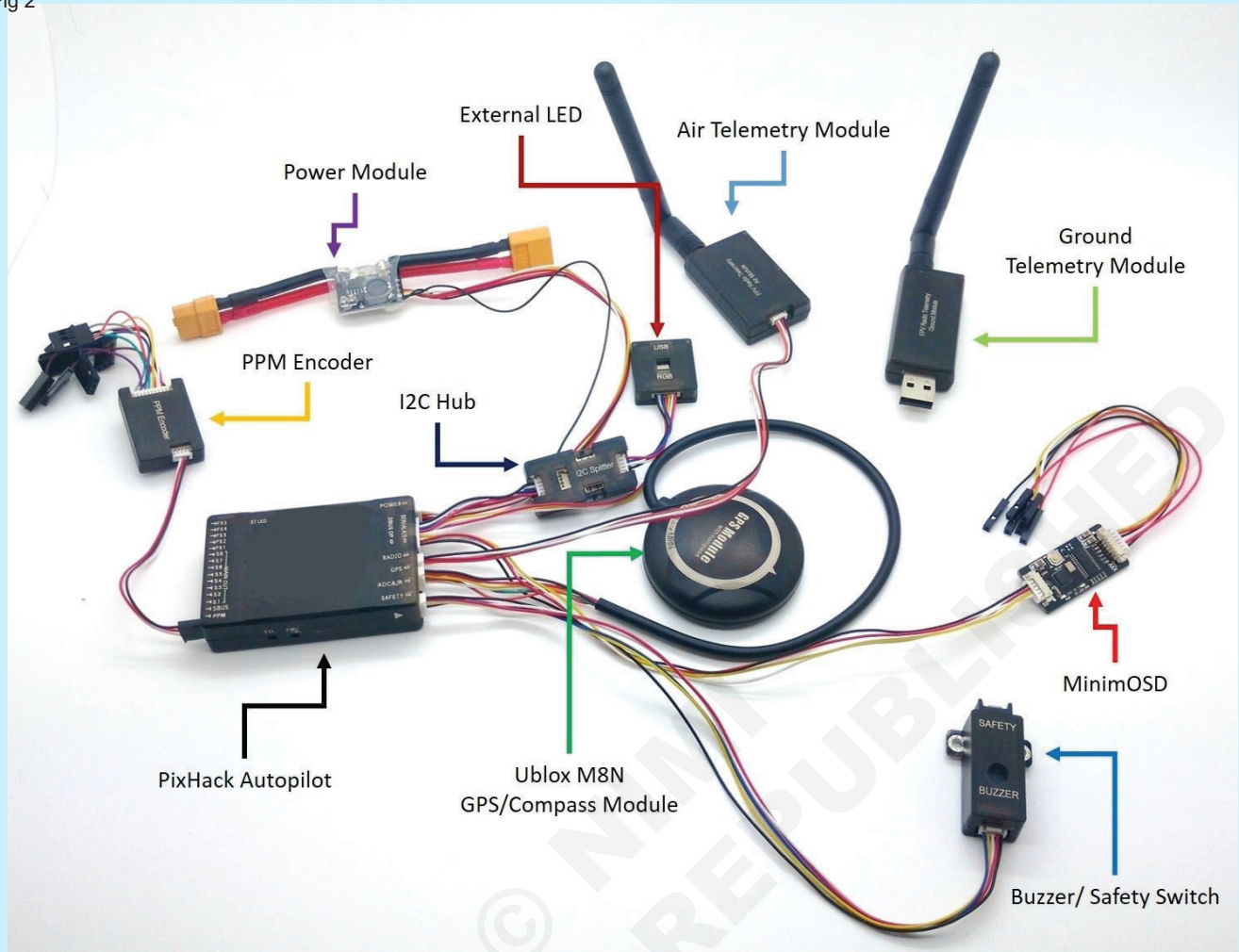

Fig 2



Perform takeoff/Landing operation and identify faults in system

Objectives : At the end of this exercise you shall be able to

- practice drone flying
- visualize fault in drone.

PROCEDURE**Practice and Visualize faults in system**

- 1 Take trainee to drone flying field
- 2 Connect drone and start flying
- 3 After landing take down and visualize it
- 4 Find the fault with proper visualization
- 5 Fill table 1 and get corrected by the instructor

Table 1

S.No	Types of Faults	Description
1		
2		
3		
4		
5		
6		